

## Pioneers in Fluid Power

Established in 1912, FULFLO was incorporated in 1933 under its present name and trademark. Patents for the original guided piston, direct-acting relief valve were obtained in 1935, coincident with the onset of fluid power systems. The need for providing large flows without excessive bulk was subsequently met by the pilot-valve-controlled relief valve, a patent on which was issued to FULFLO in 1943 (U.S. Patent No. 2,333,522).

FULFLO is located in Blanchester, Ohio just 30 miles northeast of Cincinnati, close to some of the state's

largest manufacturing centers. Blanchester is served by air from Greater Cincinnati Airport and alternately from Dayton Municipal Airport.

From Cincinnati, travel Interstate 71 north to Interstate 275, east to US 28 and northeast to Blanchester.

From Dayton, travel Interstate 75 south to Route 123 and southeast to Blanchester.

If you plan to visit FULFLO, advise us of your itinerary and we will be happy to assist with transportation and hotel arrangements.

## TERMS AND CONDITIONS

**Product Information.** Please include complete product data as described in the catalog. **Note:** All valves will be set midrange pressure of the spring, unless otherwise specified.

**Shipping Information.** Please include purchaser's name, complete address and requested routing. Product may be shipped via U.P.S., insured parcel post or commercial motor freight.

**Guarantee.** Fulflo products are guaranteed against defects in workmanship or material for one year after date of shipment. Fulflo is not liable for any damages resulting from misuse or misapplication of its product.

**Specifications.** For continued improvement of our product line, we reserve the right to change product specifications without prior notice.

**Cancellations.** Charges are based on work accomplished prior to the receipt of cancellation.

**Returned Material.** An RGA (Return Goods Authorization) Number **must** be issued before returning any product.

**Restocking.** Product returned is subject to a restocking charge. Restocking fee is 25% of List Price on standard product line. Special products are subject to additional charges.

**Prices.** F.O.B. Blanchester, Ohio. Prices are subject to change without notice.

**Terms.** Net 30 days to buyers with approved credit; all other shipments are C.O.D.

**Invoicing.** Buyers will be invoiced by Fulflo Specialties, 459 E. Fancy Street, Blanchester, Ohio 45107.

**Delivery.** Deliveries are scheduled after receipt of orders which should include all required technical information. Shipping dates are **estimated** based on conditions prevailing at the time of quotation, but are not guaranteed. Fulflo shall not be liable for delays in delivery due to causes beyond its reasonable control. Fulflo shall not be liable for any special or consequential damages caused by or resulting from delay, failure to manufacture or deliver.

**Minimum Order.** Minimum order charge required is \$25.00.

**Expediting Fee.** Orders may be subject to a 15% expediting fee.

**Change Order Fee.** There is a \$25.00 change order fee, per order.

DUE TO ENGINEERING UPGRADING, THE DIMENSIONS AND SPECIFICATIONS ARE SUBJECT TO CHANGE, BUT ARE CORRECT HERE AT TIME OF PRINTING.

# CONTENTS

## FULFLO

### ENGINEERING DATA

### V-SERIES VALVES

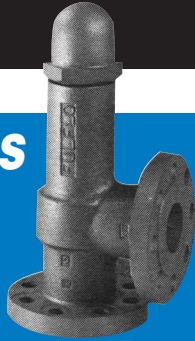

### FV-SERIES VALVES



### A-SERIES VALVES

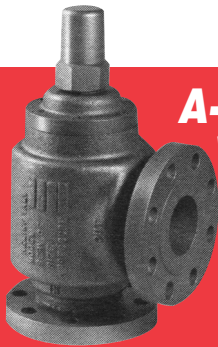

### SVB SERIES VALVES

### APPLICATIONS

### SPECIALTY VALVES

**OUR MISSION STATEMENT:** *Fulflo Specialties will strive to be the world leader in the valve manufacturing industry. Our mission is to achieve and sustain through continuous improvement, the highest quality of product and services. Fulflo will ensure that every employee, vendor, and subcontractor share a common goal of quality and reliability at an affordable price.*

General Information	2
Terms & Conditions	2

#### ENGINEERING DATA

Valve Design Characteristics	4
Valve Sizing-Use of Performance Charts	4
Pipe Sizing-Use of the Nomograph	5
Application Diagrams	6
Spring Material & Temperature Chart	7
Connections	8
SAE O-Ring Boss	8
Socket Weld	9
Standard Materials	9
ASTM/ASME Specifications	9
Material Codes	9
O-Ring and Pad Materials	9
Max Temp. Max Pressure	9
Orifice Area & Piston/Body Tolerances	9
Flange and Drilling Dimensions	10

#### V-SERIES VALVE

Application and Installation	11
Valve Setting – Maintenance – Disassembly	12
Assembly Number Identification Chart	13
Standard Spring Pressure Range Chart	13
Dimensions and Parts List	14-15
VJ, VB, VS, VSS, VJ-SP	14-15
VJF, VBF, VSF, VSSF, VJF-SP	14-15
HVJ, HVB, HVS, HVSS	16-17
HVJ-P, HVB-P, HVS-P, HVSS-P	16-17
HVJF, HVBF, HVSF, HVSSF	16-17
HVJF-P, HVBF-P, HVSF-P, HVSSF-P	16-17
Performance Charts	18-19
Performance Charts	18-19

#### FV-SERIES VALVE

Application and Installation	20
Valve Setting – Maintenance – Disassembly	21
Assembly Number Identification Chart	22
Standard Spring Pressure Range Chart	22
Dimensions and Parts List	23-24
FVJ, FVB, FVS, FVSS	23-24
FVJF, FVBF, FVSF, FVSSF	23-24
Performance Charts	25-26
Performance Charts	25-26

#### A-SERIES VALVES

Application and Installation	27
Valve Setting – Maintenance – Disassembly	28
Model Number and Ordering Information	29
Standard Spring Pressure Range Chart	29
Direct Acting Valves	29
Dimensions and Parts List	30-31
AAD, ACD	30-31
AADF, ACDF	30-31
Performance Charts	32
Internal Pilot Operated Valves	32
Disassembly	34-35
Dimensions and Parts List	34-35
AAP, ACP	34-35
AAPF, ACPF	34-35
Performance Charts	36

#### SVB-SERIES VALVES (Underwriter Listed)

Application and Installation	37
Maintenance – Disassembly	38
Valve Setting	39
Model Number and Ordering Information	40
Standard Spring Pressure Range Chart	40
Dimensions and Parts List	40
Performance Charts	41-42
Performance Charts	41-42

#### APPLICATIONS

Typical Applications	43
----------------------	----

Please contact Fulflo direct for special applications. We provide special valves or modified valves to meet your application.

# VALVE SIZING...Use of Performance Charts

## FULFLO GUIDED PISTON VALVES

The trademark FULFLO expresses the basic principle that the relief valve must have flow capacity equal to that of the pipe lines to which it is connected. The sliding piston concept and internal design contours of FULFLO valves provide unique flow and stability characteristics for reliable performance without chatter.

FULFLO valves are designed to operate reliably at pressures as low as 2 PSI and as high as 1000 PSI. The FULFLO valve reduces velocities through all but the controlling interface of the valve thereby minimizing system power loss.

Unlike ordinary direct acting relief valves, FULFLO guided piston valves are less responsive to transient pressure surges thereby eliminating the tendency to pound, squeal or chatter. Quiet, stable, efficient performance is assured in both load regulation and system protection applications.

FULFLO valves operate effectively with all types of liquids in the full range of viscosities including hydraulic oils, water, solvents and chemicals.

FULFLO valves are not designed to be positive shut off, and will pass a minimal amount of leakage before the set pressure.

FULFLO valves are NOT designed for use with air, gas or steam.

Since the FULFLO relief valve is a flow-modulating device, pressure flow characteristics are completely different from spring loaded poppet or ball check valves. Both types remain substantially tight up to *cracking pressure*. When this pressure is exceeded, the "conventional" valve pops open with a pressure drop at very low flow and an exponential pressure rise as the flow increases.

In contrast the FULFLO valve causes a pressure rise, *over-pressure*, as soon as flow starts; pressure increases almost proportionally with flow. Springs and areas on FULFLO valves are carefully designed to minimize this over-pressure.

Both pressures are important in sizing a valve. *Cracking pressure* must be selected high enough to permit system operation at its maximum rated pressure and flow. *Over-pressure* is limited by the system's capability to withstand the additional pressure and the motor's ability to sustain the pump output at the increased pressure for the required time interval.

The over-pressure to produce a certain flow is a function of valve size and spring constant and can be determined with the aid of the over-pressure charts given for the different valve sizes. The valve performance charts are based on tests made with oil of 150 SSU viscosity at 100° F and may be used with reasonable accuracy within the conventional range of oil viscosities from 30 to 500 SSU. For operation with high viscosity fluids, consult FULFLO's engineering department.

In sizing a valve, the first attempt should be to select a

valve equal in size to the pipe to which it is connected. A larger or smaller valve may be used to suit individual requirements, depending on the permissible amount of over-pressure. Assume we have selected a 3/4" valve for 17 GPM flow and a cracking pressure of 325 PSI. By referring to the pressure range chart, we find that we may use either a "YS" or a "ZS" spring.

Assuming a "YS" spring, draw a line horizontally at 17 GPM in the 3/4" valve chart, to intersect the slanted line marked "YS" and drop a vertical line to the over-pressure scale to read an over-pressure of 44 PSI. The 17 GPM will be discharged at a pressure of 325 + 44 or 369 PSI. The percentage of over-pressure would be  $44/325 \times 100$  or 13.5%.

If a "ZS" spring is used, extend the horizontal line to the "ZS" slope and the over-pressure is 70 PSI. The pressure to pass 17 GPM would be 325 + 70 or 395 PSI and the over-pressure would be 21.5%. If the over-pressure is higher than desired for the particular application, the procedure may be repeated for the next larger size valve.

In some cases, maximum flow through a valve at a given pressure is specified. To determine the cracking pressure, assume a 3/4" valve is to pass 12 GPM at 50 PSI. A horizontal line drawn from the 12 GPM capacity to the intersection with the "WS" spring line results in an over-pressure of 14 PSI, therefore the cracking pressure must be 50 - 14 or 36 PSI, and the percentage of over-pressure of only 9 PSI, but the cracking pressure would be  $14/36 \times 100$  or 38.8%. The use of a "US" spring would produce an over pressure of only 9 PSI but the cracking pressure would then be 50 - 9 or 41 PSI, which would exceed the rating of the "US" spring.

For sizing valves for higher viscosity than 500 SSU, the following formula is used:

$$4\sqrt{\frac{V_2}{V_1}} \times \text{area of valve for 150 SSU}$$

$$V_1 = 150 \text{ SSU}$$

$$V_2 = \text{higher viscosity}$$

Assume we have the following application,

$$\text{GPM} = 10$$

$$\text{Viscosity} = 12,000 \text{ SSU}$$

Normally for 10 GPM a 1/2" valve would be used. Referring to the orifice area chart on page 9, to find the area of a 1/2" valve. The area is .305.

$$4\sqrt{\frac{12000}{150}} = 4\sqrt{80} = 2.99$$

$2.99 \times .305 = .9120$  area needed to pass 10 GPM

Again referring to the orifice area chart, we find that the area of 1 1/4" valve is 1.224. Therefore a 1 1/4" valve would be used. To find the over-pressure refer to the performance chart for a 1 1/4" valve.

Performance charts based on actual test results are available on request. For additional information contact THE FULFLO SPECIALTIES CO.

# PIPE SIZING...Use of the Nomograph

The flow velocity, which must first be determined, is dependent on the viscosity of the fluid and the permissible flow resistance in the piping. Lower velocities are for higher viscosity fluids and/or lower pressure drops; higher velocities are for less viscous fluids and cases where higher pressure drops can be tolerated. In all cases, allowable suction velocities are much lower and the lowest velocities should be used for the more viscous fluids and/or higher suction lifts.

Suction velocities are much more critical than discharge velocities. Too high a discharge velocity may only result in excessive power loss but an excessive suction velocity may make the system inoperative or cause damage to the pump and system.

After the velocity has been selected, the nomograph chart is used to determine the inside diameter of the pipe at a given flow rate. For example, assume a flow of 17 gpm and a velocity of 12 fps for the discharge pipe is required. Draw a line from the 12 fps point on the velocity scale through the 17 gpm point on the flow rate scale and the extended line intersects the pipe inside diameter scale at 0.76 inches. This inside diameter applies to either pipe or tubing.

The correct pipe or tube size also depends on the pressure it must carry. The conversion chart for pipe sizes and schedules facilitates this section.

Note the different weights or piping are grouped under various schedule numbers. Approximate pressure for each schedule number may be computed from the formula.

$$\text{Pressure} = \frac{S}{1000} \times \text{schedule number}$$

S is the permissible stress to which the pipe is subjected. Thus, for a stress of 10,000 psi, the allowable pressure is equal to ten times the schedule number. Higher pressures may be carried if higher stresses are allowed.

In the example, a schedule 40 pipe is more than adequate for 250 psi. Twice the wall thickness of a 3/4" schedule 40 pipe of 0.226 or 0.976". Since the actual outside diameter of a 3/4" schedule 40 pipe is 1.05", the selection of a 3/4" pipe is adequate.

A 3/4" Fulflo relief valve should be selected. Operational characteristics of this valve, that is cracking pressure and overpressure, may be determined from the performance chart precisely in the manner explained in the example. The maximum discharge pressure of 285 psi is still well below the safe carrying capacity of the pipe. The design of the Fulflo valves is such that if used within their rating and with properly selected springs, the overpressure is not sufficient to endanger system or system components.

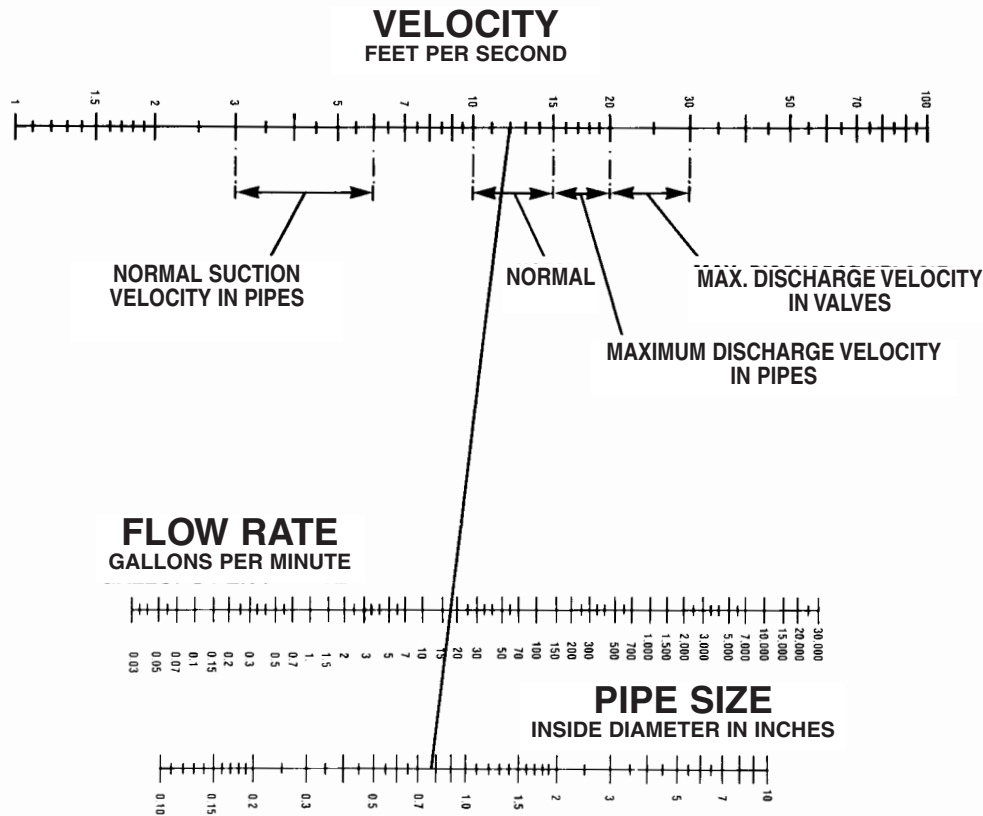

# APPLICATIONS

**SYSTEM 1**

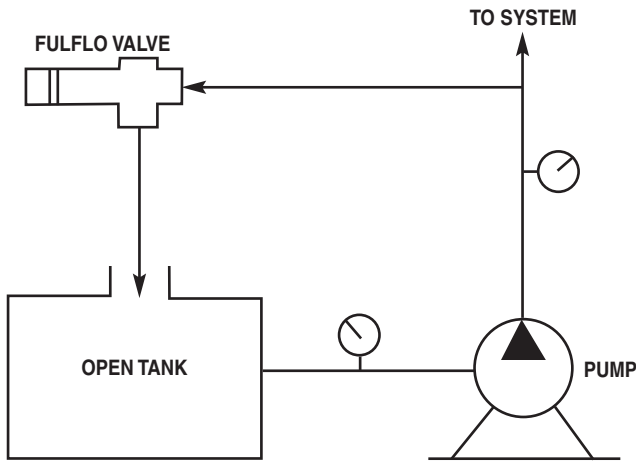

**OPEN TANK**

**VALVE SET PRESSURE EQUALS  
SYSTEM OPERATING PRESSURE**

**SYSTEM 2**

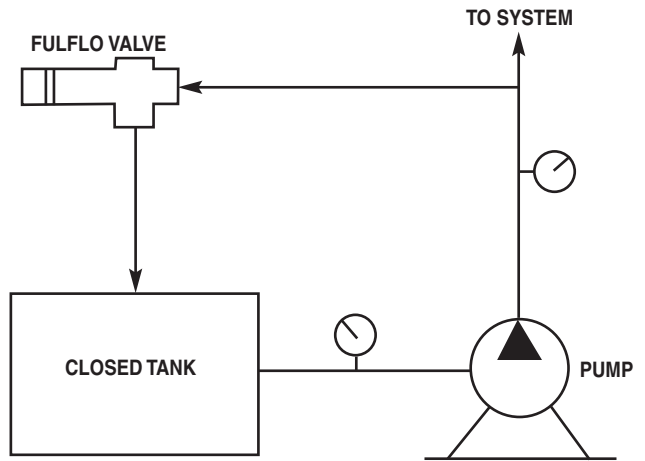

**CLOSED TANK**

**TANK PRESSURE + VALVE SET PRESSURE  
EQUALS SYSTEM OPERATING PRESSURE**

**SYSTEM 3**

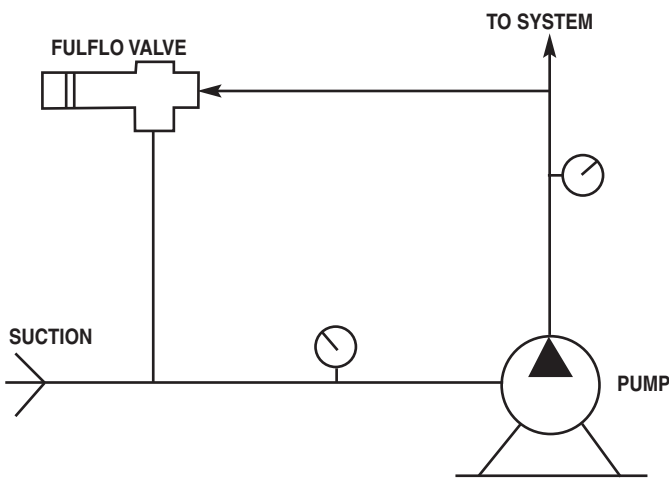

**CLOSED LOOP**

**SUCTION PRESSURE + VALVE SET PRESSURE  
EQUALS SYSTEM OPERATING PRESSURE**

**SYSTEM 4**

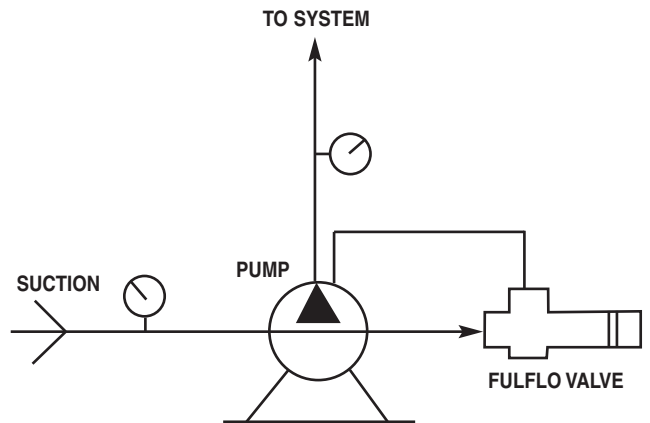

**PUMP INTERNAL RELIEF**

**FOR PUMPS WITH (2) SUCTION PORTS  
AND (2) DISCHARGE PORTS**

**SUCTION PRESSURE + VALVE SET PRESSURE  
EQUALS SYSTEM OPERATING PRESSURE**

# SPRING MATERIAL & TEMPERATURE CHART

VALVE SIZE	PART NO.	MATERIAL			MAX TEMP.				ASTM SPEC.						
		17-7PHSS	18-8SS	CHR. VANADIUM	OIL TEMP.	MUSIC WIRE	650 F	550 F	425 F	250 F	313 TYPE 631	A581 COND. A	A 231	229	228
1/4"	207-AS														
	207-US														
	207-WS														
	207-XS														
	207-YS														
	207-ZS														
	207-RS														
	207-TS														
	207-A														
	207-U														
	207-W														
	207-X														
	207-Y														
	207-Z														
3/8"	207-RS														
	207-TS														
	307-AS														
	307-US														
	307-WS														
	307-XS														
	307-YS														
	307-ZS														
	307-RS														
	307-TS														
	307-A														
	307-U														
	307-W														
	307-X														
1/2"	307-Y														
	307-Z														
	307-RS														
	307-TS														
	407-AS														
	407-US														
	407-WS														
	407-XS														
	407-YS														
	407-ZS														
	407-U														
	407-W														
	407-X														
	407-Y														
407-Z															
3/4"	507-AS														
	507-US														
	507-WS														
	507-XS														
	507-YS														
	507-ZS														
	507-A														
	507-U														
	507-W														
	507-X														
	507-Y														
	507-Z														
	507-R														

VALVE SIZE	PART NO.	MATERIAL			MAX TEMP.				ASTM SPEC.							
		17-7PHSS	18-8SS	CHR. VANADIUM	OIL TEMP.	CHROME SILICON	650 F	550 F	425 F	250 F	313 TYPE 631	A581 COND. A	A 231	229	228	
1/4"	607-AS															
	607-US															
	607-WS															
	607-XS															
	607-YS															
	607-ZS															
	607-A															
	607-U															
	607-W															
	607-Y															
	607-Z															
	607-R															
	1/2"	707-AS														
		707-US														
707-WS																
707-XS																
707YS																
707-ZS																
707-A																
707-U																
707-W																
707-X																
707-Y																
707-Z																
707-R																
2"		807-AS														
	807-US															
	807-WS															
	807-XS															
	807-YS															
	807-ZS															
	807-A															
	807-U															
	807-W															
	807-X															
	807-Y															
	807-Z															
	2 1/2"	A0960D														
		A0961C														
A0970D																
A0971C																
A0980D																
A1060D																
3"	A1061C															
	A1070D															
	A1071C															
	A1080D															
	A1160D															
	A1170D															
4"	A1181D															
	A1190D															



# SAE O-RING BOSS CONNECTIONS

VALVE SIZE	SAE NUMBER								
	5	6	8	10	12	16	20	24	32
3/8"	X	X	X						
1/2"		X	X	X					
3/4"				X	X				
1"					X	X	X		
1 1/4"							X	X	
1 1/2"								X	
2"									X

SAE (Society Automotive Engineers)

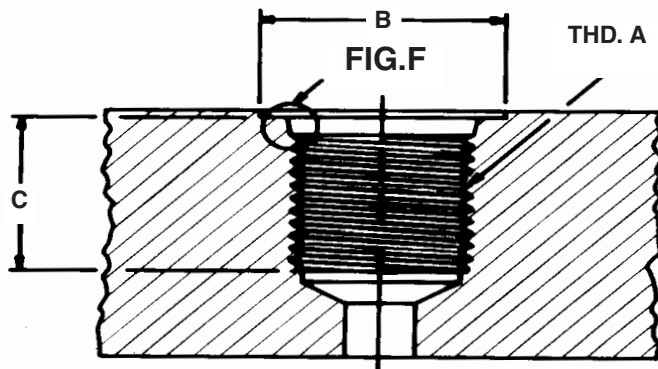

DIMENSIONS (INCHES)

SAE NO.	A	B	C	D	E
5	1/2"-20	.937	.547	.550	12°F
6	9/16"-18	1.000	.609	.616	12°F
8	3/4"-16	1.218	.688	.811	12°F
10	7/8"-14	1.375	.781	.942	15°F
12	1 1/16"-12	1.656	.906	1.148	15°F
16	1 5/16"-12	2.000	.906	1.398	15°F
20	1 5/8"-12	2.312	.906	1.713	15°F
24	1 7/8"-12	2.562	.906	1.962	15°F
32	2 1/2"-12	3.192	.906	2.587	15°F

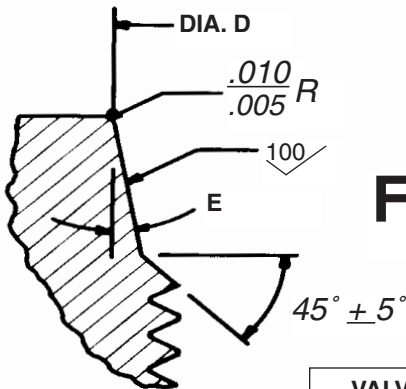

FIG. F

VALVE SIZE	SAE NO.	MATERIAL			
		CAST IRON	BRASS	STEEL	STAINLESS
3/8"	5	SVJ-2039	SVB-2039	SVS-2039	SVSS-2039
	6	SVJ-2036	SVB-2036	SVS-2036	SVSS-2036
	8	SVJ-2042	SVB-2042	SVS-2042	SVSS-2042
1/2"	6	SVJ-3065	SVB-3065	SVS-3065	SVSS-3065
	8	SVJ-3066	SVB-3066	SVS-3066	SVSS-3066
	10	SVJ-3051	SVB-3051	SVS-3051	SVSS-3051
3/4"	10	SVJ-4041	SVB-4041	SVS-4041	SVSS-4041
	12	SVJ-4049	SVB-4049	SVS-4049	SVSS-4049
1"	12	SVJ-5084	SVB-5084	SVS-5084	SVSS-5084
	16	SVJ-5071	SVB-5071	SVS-5071	SVSS-5071
	20	SVJ-5083	SVB-5083	SVS-5083	SVSS-5083
1 1/4"	20	SVJ-6065	SVB-6065	SVS-6065	SVSS-6065
	24	SVJ-6066	SVB-6066	SVS-6066	SVSS-6066
1 1/2"	24	SVJ-7050	SVB-7050	SVS-7050	SVSS-7050
2"	32	SVJ-8047	SVB-8047	SVS-8047	SVSS-8047

# SOCKET WELD & STANDARD MATERIALS

## SOCKET WELD

VALVE SIZE	MODEL NUMBER		AA		BB
	STEEL	STAINLESS	MIN.	MAX.	
3/8"	SVS-2033	SVSS-2033	.685	.690	.312
1/2"	SVS-3037	SVSS-3037	.850	.855	.437
3/4"	SVS-4038	SVSS-4038	1.060	1.065	.562
1"	SVS-5024	SVSS-5024	1.325	1.330	.625
1 1/4"	SVS-6058	SVSS-6058	1.670	1.675	.750
1 1/2"	SVS-7067	SVSS-7067	1.910	1.915	.812
2"	SVS-8070	SVSS-8070	2.410	2.415	.875

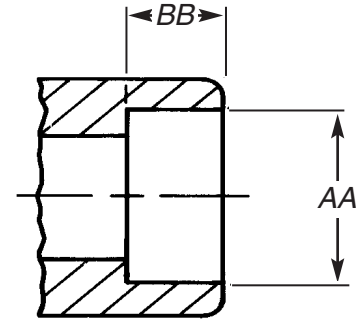

## ASTM/ASME SPECIFICATIONS

### Adjusting Screws

### Stop Rings, Glands, Bonnets

Brass – ASTM B16  
 Steel – ASTM 108-79  
 Stainless Steel – ASME ASME SA479 Class 316

### Caps

Cast Iron – 401 thru 801 ASTM A 126-42 Class A  
 Brass – 201-B thru 501-B ASTM B16  
 Brass – 601B thru 801-B ASME B62  
 Steel – All models ASTM 108-79  
 Stainless Steel – All models ASME SA479 Class 316

### Locknuts, Retainers

Steel – ASTM 108-79  
 Stainless Steel – ASTM A582 Class 303  
 Brass – ASTM B16

### Pistons

Hardened Steel – ASTM 108-79  
 416 Stainless Steel – ASTM A 582 Cond. A  
 303 Stainless Steel – ASTM A 582 Class 303

### Bodies

Cast Iron – ASTM A126-42 Class A  
 Brass – ASME B62  
 Steel – ASTM A 216 Grade WCB  
 Stainless Steel – ASTM A 351 CF8M

### Material Codes

(Unless Otherwise Specified)

A – 416 Stainless Steel  
 J – Cast Iron (No Part # Suffix)  
 B – Brass  
 S – Steel  
 SS – Stainless Steel

## O-RING & PAD MATERIAL SPECIFICATIONS

MATERIAL	SUFFIX CODE	COMPOUND	TEMP. RANGE		ASTM SPEC.
			MIN.	MAX.	
BUNA	R	B 46	-40°F	257°F	D2000
ETHYLENE-PROPYLENE	EPR	E 50	-67°F	302°F	D2000
VITON	RV	V 14	-31°F	437°F	D2000
SILICONE	RS	S 71	-103°F	482°F	D2000
TEFLON	RT	--	-423°F	500°F	D2000
NEOPRENE	RN	--	-67°F	284°F	D2000
AFLAS	RA	--	-25°F	450°F	D2000

## MAXIMUM TEMP. OF BODIES

MATERIAL	TEMPERATURE
CAST IRON	400°F
BRASS	400°F
STEEL	600°F
STAINLESS STEEL	600°F

## MAXIMUM ALLOWABLE WORKING PRESSURE

CAST IRON	1500 PSI
BRASS	1500 PSI
STEEL	2000 PSI
STAINLESS STEEL	2000 PSI

## ORIFICE AREA & PISTON/BODY TOLERANCES

DIMENSIONS IN INCHES

VALVE SIZE	PISTON DIA. ±.000-.0003	AREA IN 2	BODY GO RC 3 FIT	BODY NO GO RC 3 FIT
1/4	.4985	.195	.4993	.4999
3/8	.4985	.195	.4993	.4999
1/2	.6235	.305	.6243	.6249
3/4	.7485	.440	.7493	.7499
1	.9985	.783	.9993	1.0003
1 1/4	1.2485	1.224	1.2495	1.2507
1 1/2	1.4985	1.764	1.4995	1.5007
2	1.9985	3.167	1.9997	2.0011
2 1/2	2.6500	5.515	2.6517	2.6527
3	3.1235	7.663	3.1247	3.1261
4	4.1222	13.346	4.1250	4.1262



# FLANGE AND DRILLING DIMENSIONS (INCHES)

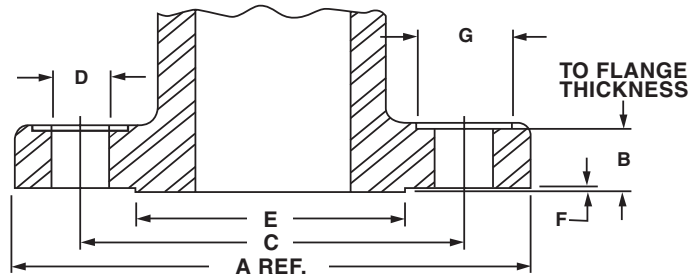

## CLASS 150 (BRASS – CAST IRON – STEEL – STAINLESS STEEL)

Valve Size	A Flange Diameter	B Flange Thickness		C Bolt Circle Diameter	D Bolt Holes Diameter	E Raised Face Diameter	F Raised Face Height	G Spotface Diameter	Number of Bolts
		Brass	CI/Steel						
1"	4 <sup>1</sup> / <sub>4</sub> "	3/8"	9/16"	3 <sup>1</sup> / <sub>8</sub> "	5/8"	2"	1/16"	1.12	4
1 <sup>1</sup> / <sub>4</sub> "	4 <sup>5</sup> / <sub>8</sub> "	13/32"	1/2"	3 <sup>1</sup> / <sub>2</sub> "	5/8"	2 <sup>1</sup> / <sub>2</sub> "	1/16"	1.12	4
1 <sup>1</sup> / <sub>2</sub> "	5"	7/16"	9/16"	3 <sup>7</sup> / <sub>8</sub> "	5/8"	2 <sup>7</sup> / <sub>8</sub> "	1/16"	1.12	4
2"	6"	1/2"	5/8"	4 <sup>3</sup> / <sub>4</sub> "	3/4"	3 <sup>5</sup> / <sub>8</sub> "	1/16"	1.37	4
2 <sup>1</sup> / <sub>2</sub> "*	7"	N/A	11/16"	5 <sup>1</sup> / <sub>2</sub> "	3/4"	4 <sup>1</sup> / <sub>8</sub> "	1/16"	1.37	4
3"*	7 <sup>1</sup> / <sub>2</sub> "	N/A	3/4"	6"	3/4"	5"	1/16"	1.37	4
4"*	9"	N/A	15/16"	7 <sup>1</sup> / <sub>2</sub> "	3/4"	6 <sup>3</sup> / <sub>16</sub> "	1/16"	1.37	8

**Note:** Brass flanges conform to 150# ANSI B 16.24 *except* with raised face. Cast iron and steel flanges conform to 150# ANSI B 16.5 steel specifications.  
\*Available in Cast Iron & Steel only. 125-250 AARH flange finish (Steel & Stainless Steel only)

## CLASS 250 (CAST IRON)

Valve Size	A Flange Diameter	B Flange Thickness	C Bolt Circle Diameter	D Bolt Holes Diameter	E Raised Face Diameter	F Raised Face Height	G Spotface Diameter	Number of Bolts
1"	4 <sup>7</sup> / <sub>8</sub> "	11/16"	3 <sup>1</sup> / <sub>2</sub> "	3/4"	2 <sup>11</sup> / <sub>16</sub> "	1/16"	1.37	4
1 <sup>1</sup> / <sub>4</sub> "	5 <sup>1</sup> / <sub>4</sub> "	3/4"	3 <sup>7</sup> / <sub>8</sub> "	3/4"	3 <sup>1</sup> / <sub>16</sub> "	1/16"	1.37	4
1 <sup>1</sup> / <sub>2</sub> "	6 <sup>1</sup> / <sub>8</sub> "	13/16"	4 <sup>1</sup> / <sub>2</sub> "	7/8"	3 <sup>9</sup> / <sub>16</sub> "	1/16"	1.56	4
2"	6 <sup>3</sup> / <sub>4</sub> "	7/8"	5	3/4"	4 <sup>3</sup> / <sub>16</sub> "	1/16"	1.37	8

**Note:** Cast iron flanges conform to 250# ANSI B 16.2 steel specifications.

## CLASS 300 (BRASS – STEEL – STAINLESS STEEL)

Valve Size	A Flange Diameter	B Flange Thickness	C Bolt Circle Diameter	D Bolt Holes Diameter	E Raised Face Diameter	F Raised Face Height	G Spotface Diameter	Number of Bolts
1"	4 <sup>7</sup> / <sub>8</sub> "	11/16"	3 <sup>1</sup> / <sub>2</sub> "	3/4"	2"	1/16"	1.37	4
1 <sup>1</sup> / <sub>4</sub> "	5 <sup>1</sup> / <sub>4</sub> "	3/4"	3 <sup>7</sup> / <sub>8</sub> "	3/4"	2 <sup>1</sup> / <sub>2</sub> "	1/16"	1.37	4
1 <sup>1</sup> / <sub>2</sub> "	6 <sup>1</sup> / <sub>8</sub> "	13/16"	4 <sup>1</sup> / <sub>2</sub> "	7/8"	2 <sup>7</sup> / <sub>8</sub> "	1/16"	1.56	4
2"	6 <sup>3</sup> / <sub>4</sub> "	7/8"	5"	3/4"	3 <sup>5</sup> / <sub>8</sub> "	1/16"	1.37	8
2 <sup>1</sup> / <sub>2</sub> "	7 <sup>3</sup> / <sub>4</sub> "	1"	5 <sup>7</sup> / <sub>8</sub> "	7/8"	4 <sup>1</sup> / <sub>8</sub> "	1/16"	1.56	8
3"	8 <sup>1</sup> / <sub>2</sub> "	1 <sup>1</sup> / <sub>8</sub> "	6 <sup>5</sup> / <sub>8</sub> "	7/8"	5"	1/16"	1.56	8
4"	10"	1 <sup>1</sup> / <sub>4</sub> "	7 <sup>1</sup> / <sub>8</sub> "	7/8"	6 <sup>3</sup> / <sub>16</sub> "	1/16"	1.56	8

**Note:** Available in steel and cast iron only. Brass flanges conform to 300# ANSI B 16.24 *except* with raised face.  
Steel flanges conform to 300# ANSI B 16.5 steel specifications. 125-250 AARH flange finish (Steel & Stainless Steel only)

## CLASS 600 (CAST IRON – STEEL – STAINLESS STEEL)

Valve Size	A Flange Diameter	B Flange Thickness	C Bolt Circle Diameter	D Bolt Holes Diameter	E Raised Face Diameter	F Raised Face Height	G Spotface Diameter	Number of Bolts
1"	4 <sup>7</sup> / <sub>8</sub> "	11/16"	3 <sup>1</sup> / <sub>2</sub> "	3/4"	2"	1/4"	1.37	4
1 <sup>1</sup> / <sub>4</sub> "	5 <sup>1</sup> / <sub>4</sub> "	13/16"	3 <sup>7</sup> / <sub>8</sub> "	3/4"	2 <sup>1</sup> / <sub>2</sub> "	1/4"	1.37	4
1 <sup>1</sup> / <sub>2</sub> "	6 <sup>1</sup> / <sub>8</sub> "	7/8"	4 <sup>1</sup> / <sub>2</sub> "	7/8"	2 <sup>7</sup> / <sub>8</sub> "	1/4"	1.56	4
2"	6 <sup>1</sup> / <sub>2</sub> "	1"	5"	3/4"	3 <sup>5</sup> / <sub>8</sub> "	1/4"	1.37	8
2 <sup>1</sup> / <sub>2</sub> "	7 <sup>3</sup> / <sub>4</sub> "	1 <sup>1</sup> / <sub>8</sub> "	5 <sup>7</sup> / <sub>8</sub> "	7/8"	4 <sup>1</sup> / <sub>8</sub> "	1/4"	1.56	8
3"	8 <sup>1</sup> / <sub>2</sub> "	1 <sup>1</sup> / <sub>4</sub> "	6 <sup>5</sup> / <sub>8</sub> "	7/8"	5"	1/4"	1.56	8
4"	10 <sup>3</sup> / <sub>4</sub> "	1 <sup>1</sup> / <sub>2</sub> "	8 <sup>1</sup> / <sub>2</sub> "	1"	6 <sup>3</sup> / <sub>16</sub> "	1/4"	1.78	8

**Note:** Cast iron and steel flanges conform to 600# ANSI B 16.5 steel specifications. 125-250 AARH flange finish (Steel & Stainless Steel only)  
**Note:** Special Flanges With Drilling On Or Off Center And Smooth Or Raised Face Are Available Upon Request.

# V-SERIES VALVES

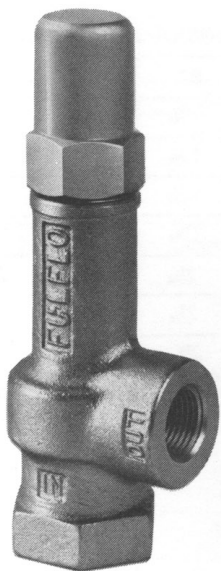

Standard  
with Screw  
Connections



Standard  
with Flange  
Connections

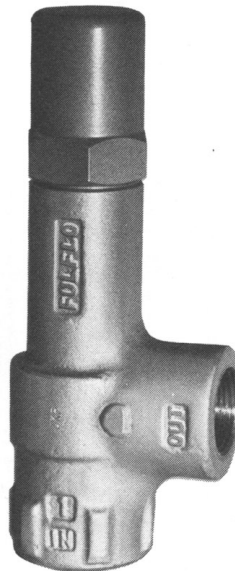

Stainless Steel  
with Screw  
Connections



Handwheel  
with Screw  
Connections

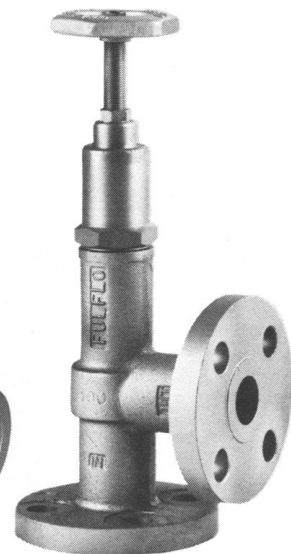

Handwheel  
with Flange  
Connections

## APPLICATION

The Fulflo "V" Series range in size from 1/4" through 2" and operate efficiently with liquids of any viscosity at pressures from 2 to 1000 P.S.I. The "V" series valves are available in flange or screw type...cartridge or handwheel in a choice of brass, cast iron, steel and stainless steel.

Widely used in a variety of applications, the "V" series valves are ideally suited in hydraulic and lubricating systems for load regulation and system protection. Special trim or packings are available for use with fire resisting fluids and other liquids of this type. Unusual applications and special requirements should be referred to our engineering staff for recommendation.

## INSTALLATION

Fulflo valves can be mounted in any position. A tee may be inserted in the pump discharge line to mount the valve. The correct size of valve should be installed, preferably matching the pump discharge line. Screw the valve into the nipple in the tee, or in the case of the flange style, bolt the valve to the companion flange screwed into the nipple. When the valve is used for frequent bypassing of oil pressure, its outlet

should be piped back to the tank. Care must be taken to have the discharge well below the oil level in the tank to prevent air entrainment and erratic operation.

Only if the valve is used as safety or overload relief and operates infrequently may its discharge be piped back into the pump suction line. Frequent or continuous operation under these conditions will cause excessive heating of the oil and possible damage.

## SETTING VALVES

Valves may be set with a hydraulic hand pump for cracking pressure. If a test stand is available, valve should be connected to the discharge header with the pump bypass open, and the bypass gradually closed until the desired pressure registers on the gauge. Adjust valve adjusting screw until valve slightly bleeds at the set bypass pressure and lock adjusting screw.

Fulflo valves are not designed to be positive shut-off, and will pass a minimal amount of leakage before the set pressure. If a valve is required to bypass a given amount of fluid at a given pressure, a test stand

having a flow meter in the pump discharge line must be available. With a valve adjusted for cracking pressure as above, continue closing bypass until the required flow registers on the flow meter and observe pressure. Readjust pressure, if necessary, to obtain desired pressure at desired flow.

## MAINTENANCE

Fulflo valves provide reliable “chatter-free” operation when the system is free of abrasives and foreign matter. Continuous filtration of the liquid used is strongly recommended.

## TYPICAL DISASSEMBLY OF STANDARD TYPE VALVE

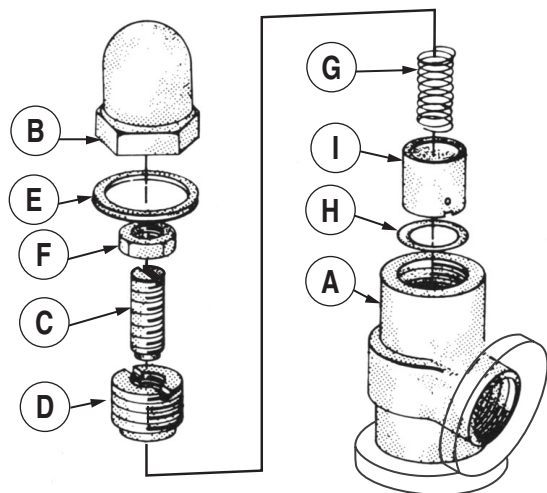

To dismantle valve for inspection or cleaning:

1. Remove cap “B”
2. Remove O-Ring “E”
3. Remove lock nut “F”
4. Remove adjusting screw “C”
5. Remove retainer “D”
6. Remove spring “G”
7. Remove piston “I”
8. Remove stop ring “H” (Not Recommended)  
(Special tooling is required to install new stop ring.)

Inspect valve bore and piston for wear and scoring. Replace broken or damaged parts. Clean all parts thoroughly and re-assemble by reversing the above procedure.

## TYPICAL DISASSEMBLY OF HANDWHEEL TYPE VALVE

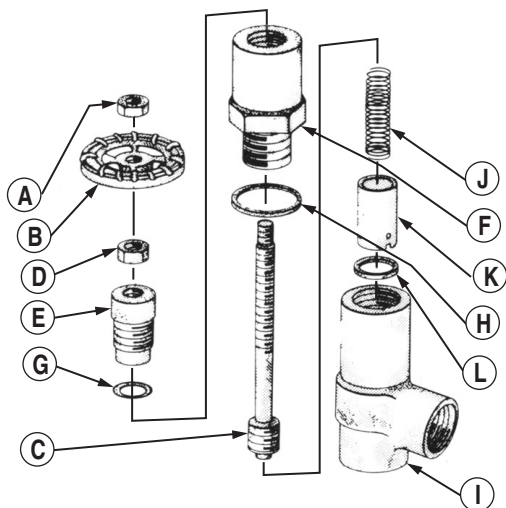

To dismantle the valve for inspection or cleaning:

1. Release spring tension by backing off handwheel as far as it will go.
2. Remove lock nut “A” or set screw and take off handwheel “B”
3. Remove lock nut “D”
4. Unscrew and remove gland “E”
5. Unscrew and remove bonnet “F”
6. Remove O-Ring “H”
7. Remove adjusting screw “C” (turn clockwise and pull out from bottom of bonnet “F”)
8. Remove O-ring packing “G”
9. Remove spring “J”
10. Remove piston “K”
11. Remove stop ring “L” (Not Recommended)  
(Special tooling is required to install new stop ring.)

Inspect valve bore and piston for wear or scoring. Replace broken or damaged parts. Clean all parts thoroughly and re-assemble by reversing the above procedure.

## ASSEMBLY NUMBER IDENTIFICATION CHART

Symbol No.	Designation	Code	Description
1	Style	None H	Standard Model Handwheel Model
2	Series	V	
3	Material	J B S SS	Cast iron Brass Steel 316 Stainless Steel
4	Connections	None F	Screw Connections Flange Connections 300# Flange Class Standard (250# Flange Class - Cast Iron Standard)
5	Size	-1 -2 -3 -4 -5 -6 -7 -8	1/4" 3/8" 1/2" 3/4" 1" 1 1/4" 1 1/2" 2"
6,7,8	ASA Flange Rating	None -150 -600	300# Flange Standard (no designation required)
9	Flange Style 150# & 600# Only	A B C D	Raised Face, Staggered Bolt Centers (standard on all Flange rating) Smooth Face, Staggered Bolt Centers Raised Face, Bolts on Valve Centerline Smooth Face, Bolts on Valve Centerline
10	O-Ring Material	R RV RS RT RA	Buna O-Ring Cap Seal (standard) Viton O-Ring Cap Seal Silicone O-Ring Cap Seal Teflon O-Ring Cap Seal (standard on VSS Series) Atlas O-Ring Cap Seal
11	Options	SP P	Steel Parts (used on cast iron only) Panel Mount on Handwheel Series
12	Piston Material	/HS /SS /3SS	Hardened Steel 416 Stainless Steel 303 Stainless Steel
13	Spring	AS US WS XS YS ZS	
14	Setting		Desired Pressure Setting

### EXAMPLES:

**VJ-1RVSP/HS/WS**

V	J	-1	RV	SP	/HS	WS
Series	Cast Iron	1/4"	Viton O-Ring	Steel Parts	H.S. Piston	WS Spring

**VJF-5R/HS/WS**

V	J	F	-5	R	/HS	WS
Series	Cast Iron	Flanged	1"	Buna O-Ring	H.S. Piston	WS Spring

**VJF-5-150AR/HS/WS**

V	J	F	-5	-150	A	R	/HS	WS
Series	Cast Iron	Flanged	1"	Rating	Style	Buna O-Ring	H.S. Piston	WS Spring

NOTE: Stainless steel pistons are supplied on brass valves, unless hardened steel is specified. Hardened steel pistons are supplied on cast iron or steel unless stainless steel is specified. Buna O-Rings are supplied as standard unless other material is specified.

### STANDARD PRESSURE RANGE CHART

Valve Pipe Size	Valve Flange Size	SPRING PRESSURE AND IDENTIFICATION NO.															
		BLACK-AS		RED-US		GREEN-WS		YELLOW-XS		WHITE-YS		BLUE-ZS		PURPLE-TS		BROWN-RS	
		Low	High	Low	High	Low	High	Low	High	Low	High	Low	High	Low	High	Low	High
1/4"		3	15	7	35	30	100	60	175	150	350	300	500	400	600	550	750
3/8"		3	15	7	35	30	100	60	175	150	350	300	500	400	600	550	750
1/2"		3	15	7	35	30	100	60	175	150	350	300	500	400	600	550	750
3/4"		3	15	7	35	30	100	60	175	150	350	300	500				
1"	1"	3	15	7	35	30	100	60	175	150	350	300	500				
1 1/4"	1 1/4"	3	15	7	35	30	100	60	175	150	350	300	500				
1 1/2"	1 1/2"	3	15	7	35	30	100	60	175	150	350	300	500				
2"	2"	3	15	7	35	30	100	60	175	150	350	250	600				

## DIMENSIONS

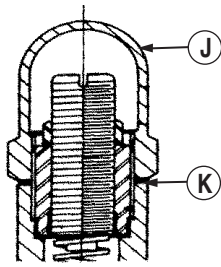

CAP  
(GASKET SEAL)

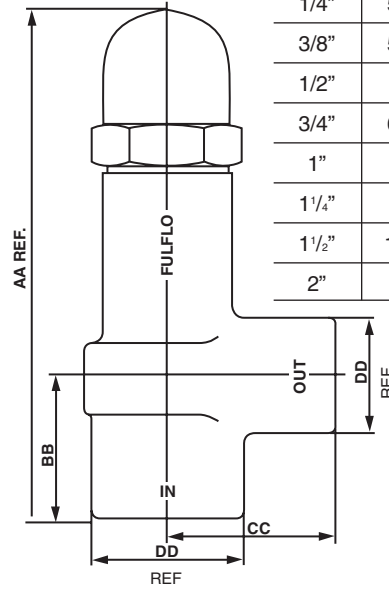
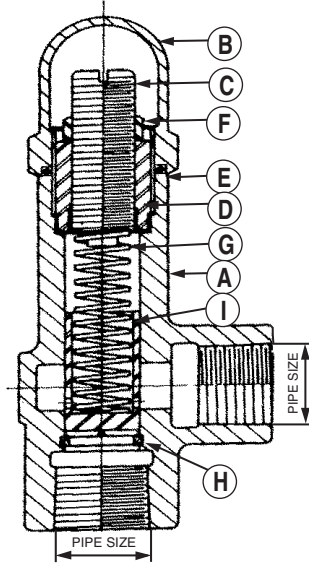

Valve Size	DIMENSIONS IN INCHES			
	AA	BB	CC	DD
1/4"	5 <sup>11</sup> / <sub>32</sub>	1 <sup>11</sup> / <sub>32</sub>	1 <sup>11</sup> / <sub>32</sub>	1 <sup>3</sup> / <sub>8</sub>
3/8"	5 <sup>11</sup> / <sub>32</sub>	1 <sup>11</sup> / <sub>32</sub>	1 <sup>11</sup> / <sub>32</sub>	1 <sup>3</sup> / <sub>8</sub>
1/2"	6 <sup>3</sup> / <sub>16</sub>	1 <sup>11</sup> / <sub>16</sub>	1 <sup>7</sup> / <sub>16</sub>	1 <sup>7</sup> / <sub>16</sub>
3/4"	6 <sup>15</sup> / <sub>16</sub>	1 <sup>15</sup> / <sub>16</sub>	1 <sup>13</sup> / <sub>16</sub>	1 <sup>11</sup> / <sub>16</sub>
1"	8 <sup>7</sup> / <sub>32</sub>	2 <sup>9</sup> / <sub>32</sub>	2 <sup>9</sup> / <sub>32</sub>	2 <sup>1</sup> / <sub>16</sub>
1 1/4"	9 <sup>9</sup> / <sub>16</sub>	2 <sup>9</sup> / <sub>16</sub>	2 <sup>9</sup> / <sub>16</sub>	2 <sup>1</sup> / <sub>2</sub>
1 1/2"	11 <sup>1</sup> / <sub>16</sub>	2 <sup>11</sup> / <sub>16</sub>	2 <sup>11</sup> / <sub>16</sub>	2 <sup>7</sup> / <sub>8</sub>
2"	13	3	3	3 <sup>1</sup> / <sub>4</sub>

## PARTS LIST

SYM.	NAME	MODEL	VALVE SIZE							
			1/4"	3/8"	1/2"	3/4"	1"	1 1/4"	1 1/2"	2"
A	BODY	VJ, VJ-SP VB VS VSS	100 100-B 100-S 100-SS	200 200-B 200-S 200-SS	300 300-B 300-S 300-SS	400 400-B 400-S 400-SS	500 500-B 500-S 500-SS	600 600-B 600-S 600-SS	700 700-B 700-S 700-SS	800 800-B 800-S 800-SS
B	CAP (O-RING SEAL)	VJ, VJ-SP VB VS VSS	201-SR 201-BR 201-SR 201-SSR	201-SR 201-BR 201-SR 201-SSR	301-SR 301-BR 301-SR 301-SSR	401-R 401-BR 401-SR 401-SSR	501-R 501-BR 501-SR 501-SSR	601-R 601-BR 601-SR 601-SSR	701-R 701-BR 701-SR 701-SSR	801-R 801-BR 801-SR 801-SSR
C	ADJUSTING SCREW	VJ, VB VS, VJ-SP VSS	202-B 202-S 202-SS	202-B 202-S 202-SS	302-B 302-S 302-SS	402-B 402-S 402-SS	502-B 502-S 502-SS	602-B 602-S 602-SS	702-B 702-S 702-SS	802-B 802-S 802-SS
D	RETAINER	VJ, VB VS, VJ-SP VSS	203-B 203-S 203-SS	203-B 203-S 203-SS	303-B 303-S 303-SS	403-B 403-S 403-SS	503-B 503-S 503-SS	603-B 603-S 603-SS	703-B 703-S 703-SS	803-B 803-S 803-SS
E	O-RING †	VJ, VJ-SP, VB, VS VSS	204-* 204-RT	204-* 204-RT	304-* 304-RT	404-* 404-RT	504-* 504-RT	604-* 604-RT	704-* 704-RT	804-* 804-RT
F	LOCK NUT	VJ, VJ-SP, VB, VS VSS	205-S 205-SS	205-S 205-SS	305-S 305-SS	405-S 405-SS	505-S 505-SS	605-S 605-SS	705-S 705-SS	805-S 805-SS
G	SPRING †	ALL MODELS	207-**	207-**	307-**	407-**	507-**	607-**	707-**	807-**
H	STOP RING	VJ, VB VS, VJ-SP VSS	208-B 208-S 208-SS	208-B 208-S 208-SS	308-B 308-S 308-SS	408-B 408-S 408-SS	508-B 508-S 508-SS	608-B 608-S 608-SS	708-B 708-S 708-SS	808-B 808-S 808-SS
I	PISTON †	HARDENED STEEL 416 STAINLESS STEEL 303 STAINLESS STEEL	206 206-A 206-SS	206 206-A 206-SS	306 306-A 306-SS	406 406-A 406-SS	506 506-A 506-SS	606 606-A 606-SS	706 706-A 706-SS	806 806-A 806-SS
J	CAP (GASKET SEAL)	VJ, VJ-SP VB VS	201-S 201-B 201-S	201-S 201-B 201-S	301-S 301-B 301-S	401 401-B 401-S	501 501-B 501-S	601 601-B 601-S	701 701-B 701-S	801 801-B 801-S
K	GASKET †	VJ, VB VS, VJ-SP	204 204-S	204 204-S	304 304-S	404 404-S	504 504-S	604 604-S	704 704-S	804 804-S

\* See o-ring selection chart

\*\* See spring pressure chart

† Recommended spare parts



## DIMENSIONS

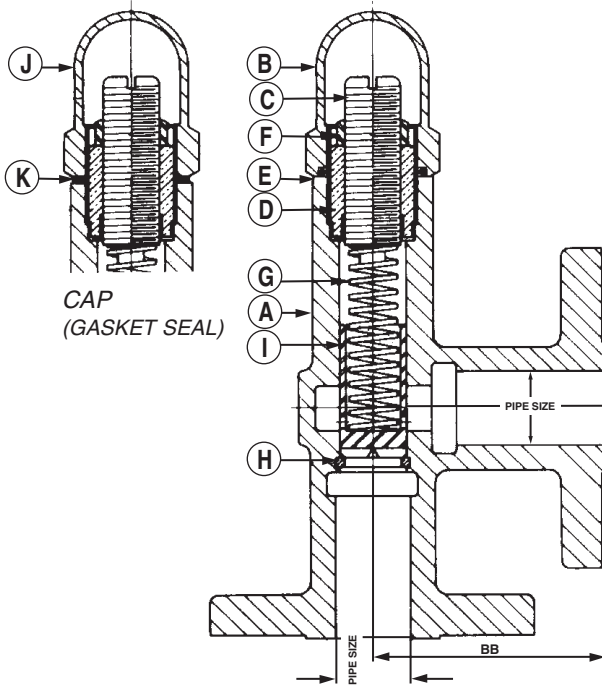

### DIMENSIONS IN INCHES

Valve Size	AA	BB
1"	9 <sup>1</sup> / <sub>2</sub> "	3 <sup>1</sup> / <sub>2</sub> "
1 <sup>1</sup> / <sub>4</sub> "	10 <sup>9</sup> / <sub>16</sub> "	3 <sup>3</sup> / <sub>4</sub> "
1 <sup>1</sup> / <sub>2</sub> "	12 <sup>7</sup> / <sub>16</sub> "	4 <sup>1</sup> / <sub>16</sub> "
2"	14 <sup>9</sup> / <sub>16</sub> "	4 <sup>9</sup> / <sub>16</sub> "

Note: Dimensions reflect 150# and 300# only

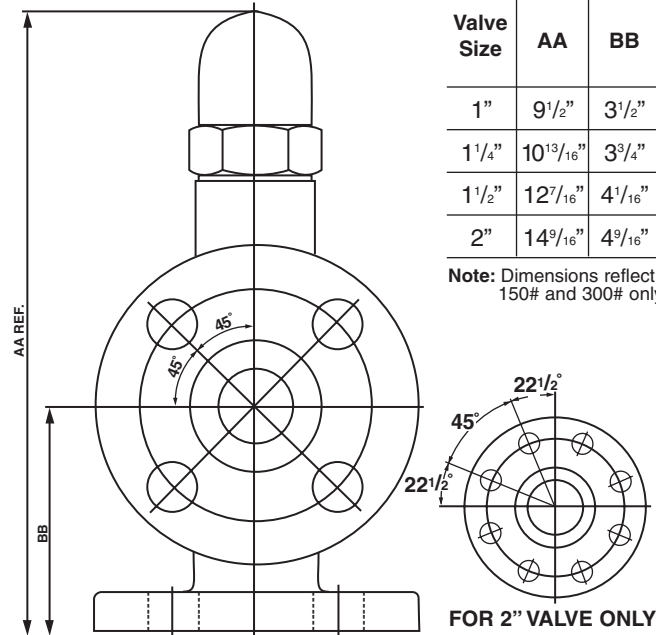

FOR 2" VALVE ONLY

## PARTS LIST

SYM.	NAME	MODEL	VALVE SIZE			
			1"	1 <sup>1</sup> / <sub>4</sub> "	1 <sup>1</sup> / <sub>2</sub> "	2"
A	BODY	VJF, VJF-SP VBF VSF VSSF	500-F 500-BF 500-SF 500-SSF	600-F 600-BF 600-SF 600-SSF	700-F 700-BF 700-SF 700-SSF	800-F 800-BF 800-SF 800-SSF
B	CAP (O-RING SEAL)	VJF, VJF-SP VBF VSF VSSF	501-R 501-BR 501-SR 501-SSR	601-R 601-BR 601-SR 601-SSR	701-R 701-BR 701-SR 701-SSR	801-R 801-BR 801-SR 801-SSR
C	ADJUSTING SCREW	VJF, VBF VSF, VJF-SP VSSF	502-B 502-S 502-SS	602-B 602-S 602-SS	702-B 702-S 702-SS	802-B 802-S 802-SS
D	RETAINER	VJF, VBF VSF, VJF-SP VSSF	503-B 503-S 503-SS	603-B 603-S 603-SS	703-B 703-S 703-SS	803-B 803-S 803-SS
E	O-RING †	VJF, VJF-SP VBF, VSF VSSF	504* 504-* 504-RT	604* 604-* 604-RT	704* 704-* 704-RT	804* 804-* 804-RT
F	LOCK NUT	VJF, VJF-SP VBF, VSF VSSF	505-S 505-S 505-SS	605-S 605-S 605-SS	705-S 705-S 705-SS	805-S 805-S 805-SS
G	SPRING †	ALL MODELS	507-**	607-**	707-**	807-**
H	STOP RING	VJF, VBF VJF-SP, VSF VSSF	508-B 508-S 508-SS	608-B 608-S 608-SS	708-B 708-S 708-SS	808-B 808-S 808-SS
I	PISTON †	HARDENED STEEL 416 STAINLESS STEEL 303 STAINLESS STEEL	506 506-A 506-SS	606 606-A 606-SS	706 706-A 706-SS	806 806-A 806-SS
J	CAP (GASKET SEAL)	VJF, VJF-SP VBF VSF	501 501-B 501-S	601 601-B 601-S	701 701-B 701-S	801 801-B 801-S
K	GASKET †	VJF, VBF VJF-SP, VSF	504 504-S	604 604-S	704 704-S	804 804-S

\* See o-ring selection chart

\*\* See spring pressure chart

† Recommended spare parts



## DIMENSIONS

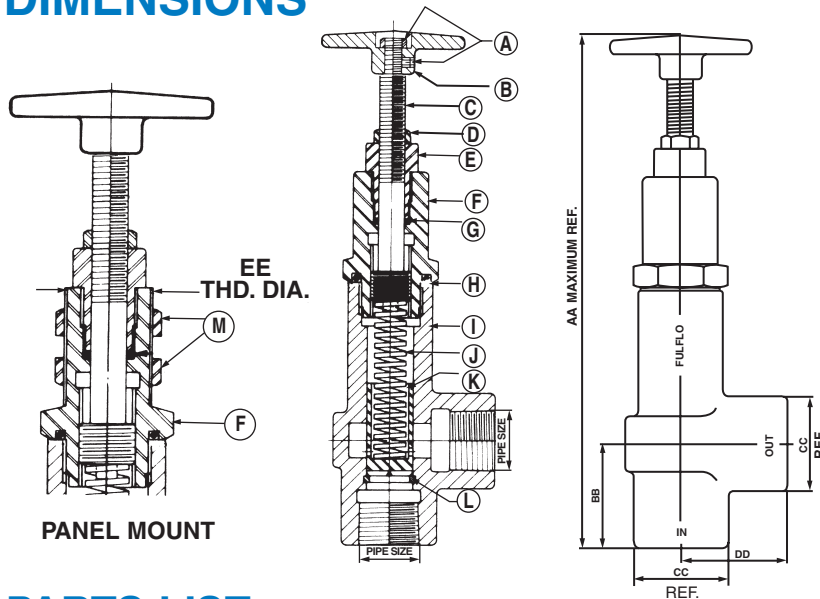

Valve Size	DIMENSIONS IN INCHES				
	AA	BB	CC	DD	EE
1/4"	8 <sup>1</sup> / <sub>8</sub>	1 <sup>11</sup> / <sub>32</sub>	1 <sup>3</sup> / <sub>16</sub>	1 <sup>3</sup> / <sub>8</sub>	7/8
3/8"	8 <sup>1</sup> / <sub>8</sub>	1 <sup>11</sup> / <sub>32</sub>	1 <sup>3</sup> / <sub>16</sub>	1 <sup>3</sup> / <sub>8</sub>	7/8
1/2"	9 <sup>5</sup> / <sub>8</sub>	1 <sup>11</sup> / <sub>16</sub>	1 <sup>7</sup> / <sub>16</sub>	1 <sup>7</sup> / <sub>16</sub>	1 <sup>1</sup> / <sub>8</sub>
3/4"	9 <sup>3</sup> / <sub>16</sub>	1 <sup>15</sup> / <sub>16</sub>	1 <sup>11</sup> / <sub>16</sub>	1 <sup>13</sup> / <sub>16</sub>	1 <sup>3</sup> / <sub>8</sub>
1"	12 <sup>7</sup> / <sub>16</sub>	2 <sup>9</sup> / <sub>32</sub>	2 <sup>1</sup> / <sub>16</sub>	2 <sup>9</sup> / <sub>32</sub>	1 <sup>3</sup> / <sub>8</sub>
1 <sup>1</sup> / <sub>4</sub> "	13 <sup>7</sup> / <sub>16</sub>	2 <sup>9</sup> / <sub>16</sub>	2 <sup>1</sup> / <sub>2</sub>	2 <sup>9</sup> / <sub>16</sub>	1 <sup>5</sup> / <sub>8</sub>
1 <sup>1</sup> / <sub>2</sub> "	17 <sup>1</sup> / <sub>16</sub>	2 <sup>11</sup> / <sub>16</sub>	2 <sup>7</sup> / <sub>8</sub>	2 <sup>11</sup> / <sub>16</sub>	2 <sup>1</sup> / <sub>4</sub>
2"	17 <sup>1</sup> / <sub>16</sub>	3	3 <sup>3</sup> / <sub>8</sub>	3	2 <sup>1</sup> / <sub>4</sub>

## PARTS LIST

SYM.	NAME	MODEL	VALVE SIZE							
			1/4"	3/8"	1/2"	3/4"	1"	1 <sup>1</sup> / <sub>4</sub> "	1 <sup>1</sup> / <sub>2</sub> "	2"
A	LOCK NUT OR SET SCREW	ALL MODELS	1/4"-20 COMM.	1/4"-20 COMM.	1/4"-20 COMM.	205-S	205-S	1/4"-20 COMM.	1/4"-20 COMM.	1/4"-20 COMM.
B	HANDWHEEL	ALL MODELS	229	229	229	429	429	629	629	629
C	ADJUSTING SCREW	HVJ(P), HVS(P) HVB(P) HVSS(P)	222-S 222-B 222-SS	222-S 222-B 222-SS	322-S 322-B 322-SS	422-S 422-B 422-SS	522-S 522-B 522-SS	622-S 622-B 622-SS	722-S 722-B 722-SS	822-S 822-B 822-SS
D	LOCK NUT	HVJ(P), HVS(P) HVB(P) HVSS(P) only	205-S 205-S 205-SS	205-S 205-S 205-SS	205-S 205-S 205-SS	305-S 305-S 305-SS	305-S 305-S 305-SS	655-S 655-S 655-SS	655-S 655-S 655-SS	655-S 655-S 655-SS
E	GLAND	HVJ(P), HVS(P) HVB(P) HVSS(P)	225-S 225-B 225-SS	225-S 225-B 225-SS	325-S 325-B 325-SS	525-S 525-B 525-SS	525-S 525-B 525-SS	625-S 625-B 625-SS	725-S 725-B 725-SS	825-S 825-B 825-SS
F	BONNET	HVJ, HVS HVB HVSS HVJP, HVSP HVBP HVSSP	223-SR 223-BR 223-SSR	223-SR 223-BR 223-SSR	323-SR 323-BR 323-SSR	423-SR 423-BR 423-SSR	523-SR 523-BR 523-SSR	623-SR 623-BR 623-SSR	723-SR 723-BR 723-SSR	823-SR 823-BR 823-SSR
G	O-RING †	HVJ(P), HVS(P) HVB(P) HVSS(P) only	224* 224* 224-RT	224* 224* 224-RT	224* 224* 224-RT	424* 424* 424-RT	424* 424* 424-RT	624* 624* 624-RT	624* 624* 624-RT	624* 624* 624-RT
H	O-RING †	HVJ(P), HVS(P) HVB(P) HVSS(P) only	204* 204* 204-RT	204* 204* 204-RT	304* 304* 304-RT	404* 404* 404-RT	504* 504* 504-RT	604* 604* 604-RT	704* 704* 704-RT	804* 804* 804-RT
I	BODY	HVJ(P) HVB(P) HVS(P) HVSS(P)	100 100-B 100-S 100-SS	200 200-B 200-S 200-SS	300 300-B 300-S 300-SS	400 400-B 400-S 400-SS	500 500-B 500-S 500-SS	600 600-B 600-S 600-SS	700 700-B 700-S 700-SS	800 800-B 800-S 800-SS
J	SPRING †	ALL MODELS	207-**	207-**	307-**	407-**	507-**	607-**	707-**	807-**
K	PISTON †	HARDENED STEEL 416 STAINLESS STEEL 303 STAINLESS STEEL	206 206-A 206-SS	206 206-A 206-SS	306 306-A 306-SS	406 406-A 406-SS	506 506-A 506-SS	606 606-A 606-SS	706 706-A 706-SS	806 806-A 806-SS
L	STOP RING	HVJ(P), HVS(P) HVB(P) HVSS(P)	208-S 208-B 208-SS	208-S 208-B 208-SS	308-S 308-B 308-SS	408-S 408-B 408-SS	508-S 508-B 508-SS	608-S 608-B 608-SS	708-S 708-B 708-SS	808-S 808-B 808-SS
M	LOCK NUTS 2 REQ'D	HVJP, HVSP, HVBP HVSSP	505-S 505-S 505-SS	505-S 505-S 505-SS	605-S 605-S 605-SS	705-S 705-S 705-SS	705-S 705-S 705-SS	805-S 805-S 805-SS	745-S 745-S 745-SS	745-S 745-S 745-SS

\* See o-ring selection chart  
 \*\* See spring pressure chart  
 † Recommended spare parts

## DIMENSIONS

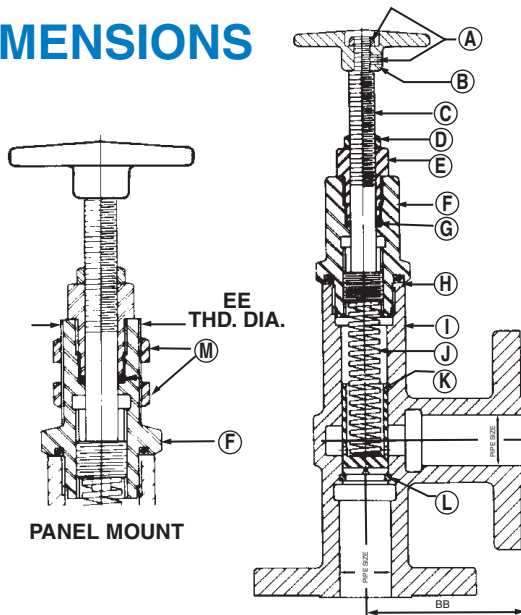

### DIMENSIONS IN INCHES

Valve Size	AA	BB	EE
1"	13 <sup>11</sup> / <sub>16</sub>	3 <sup>1</sup> / <sub>2</sub>	1 <sup>3</sup> / <sub>8</sub>
1 <sup>1</sup> / <sub>4</sub> "	14 <sup>11</sup> / <sub>16</sub>	3 <sup>3</sup> / <sub>4</sub>	1 <sup>5</sup> / <sub>8</sub>
1 <sup>1</sup> / <sub>2</sub> "	18 <sup>7</sup> / <sub>16</sub>	4 <sup>1</sup> / <sub>16</sub>	2 <sup>1</sup> / <sub>4</sub>
2"	18 <sup>5</sup> / <sub>8</sub>	4 <sup>9</sup> / <sub>16</sub>	2 <sup>1</sup> / <sub>4</sub>

Note: Dimensions reflect 150# and 300# only

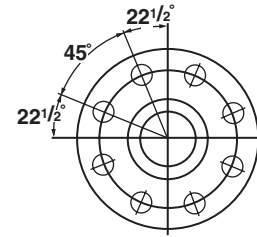

FOR 2" VALVE ONLY

## PARTS LIST

SYM.	NAME	MODEL	DIMENSIONS IN INCHES			
			1"	1 <sup>1</sup> / <sub>4</sub> "	1 <sup>1</sup> / <sub>2</sub> "	2"
A	LOCK NUT OR SET SCREW	ALL MODELS	205-S	1/4"-20 COMM.	1/4"-20 COMM.	1/4"-20 COMM.
B	HANDWHEEL	ALL MODELS	429	629	629	629
C	ADJUSTING SCREW	HVJF(P) HVSF(P) HVBF(P) HVSSF(P)	522-S 522-B 522-SS	622-S 622-B 622-SS	722-S 722-B 722-SS	822-S 822-B 822-SS
D	LOCK NUT	HVJF(P), HVSF(P) HVBF(P) HVSSF(P) only	305-S 305-S 305-SS	655-S 655-S 655-SS	655-S 655-S 655-SS	655-S 655-S 655-SS
E	GLAND	HVJF(P), HVSF(P) HVBF(P) HVSSF(P)	525-S 525-B 525-SS	625-S 625-B 625-SS	725-S 725-B 725-SS	825-S 825-B 825-SS
F	BONNET	HVJF, HVSF HVBF HVSSF HVJPF, HVSPF HVBPF HVSSFP	523-SR 523-BR 523-SSR 528-SR 528-BR 528-SSR	623-SR 623-BR 623-SSR 628-SR 628-BR 628-SSR	723-SR 723-BR 723-SSR 728-SR 728-BR 728-SSR	823-SR 823-BR 823-SSR 828-SR 828-BR 828-SSR
G	O-RING †	HVJF(P), HVSF(P) HVBF(P) HVSSF(P) only	424* 424-* 424-RT	624* 624-* 624-RT	624* 624-* 624-RT	624* 624-* 624-RT
H	O-RING †	HVJF(P), HVSF(P) HVBF(P) HVSSF(P) only	504* 504-* 504-RT	604* 604-* 604-RT	704* 704-* 704-RT	804* 804-* 804-RT
I	BODY	HVJF(P) HVBF(P) HVSF(P) HVSSF(P)	500-F 500-BF 500-SF 500-SSF	600-F 600-BF 600-SF 600-SSF	700-F 700-BF 700-SF 700-SSF	800-F 800-BF 800-SF 800-SSF
J	SPRING †	ALL MODELS	507-**	607-**	707-**	807-**
K	PISTON †	HARDENED STEEL 416 STAINLESS STEEL 303 STAINLESS STEEL	506 506-A 506-SS	606 606-A 606-SS	706 706-A 706-SS	806 806-A 806-SS
L	STOP RING	HVJF(P), HVSF(P) HVBF(P) HVSSF(P)	508-S 508-B 508-SS	608-S 608-B 608-SS	708-S 708-B 708-SS	808-S 808-B 808-SS
M	LOCK NUTS 2 REQ'D	HVJFP, HVSPF, HVBFP HVSSFP	705-S 705-S 705-SS	805-S 805-S 805-SS	745-S 745-S 745-SS	745-S 745-S 745-SS

\* See o-ring selection chart

\*\* See spring pressure chart

† Recommended spare parts

# V-SERIES PERFORMANCE CHARTS

All valve tests 110°F. to 120°F. Oil Viscosity 150 S.S.U. at 100°F.  
(Charts good from 30 to 500 S.S.U.)

V-SERIES  
VALVES

1/4" VALVE TESTS

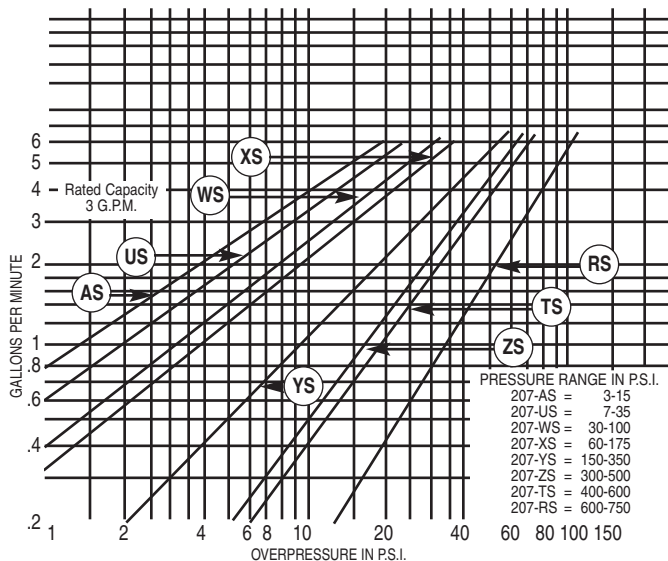

3/8" VALVE TESTS

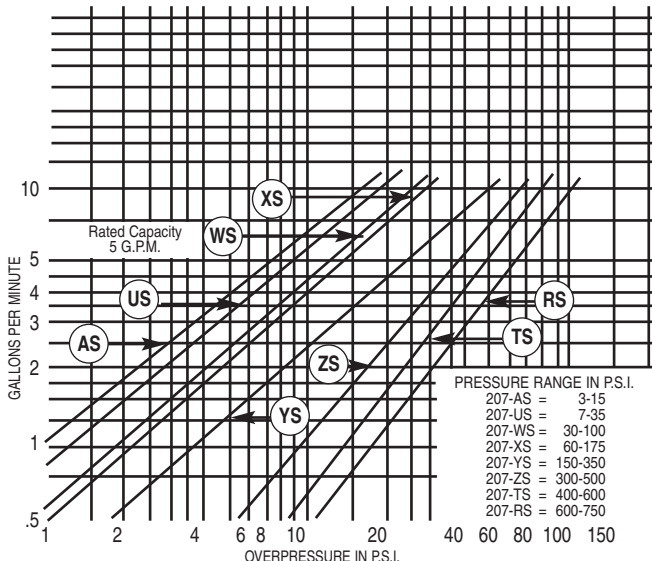

1/2" VALVE TESTS

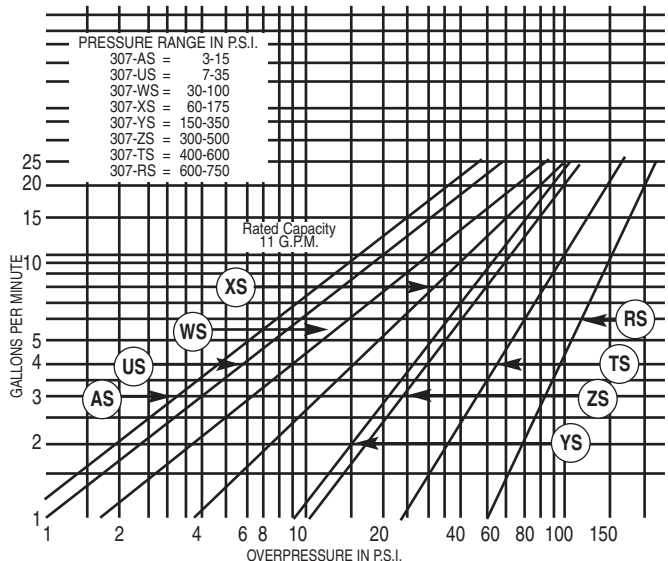

3/4" VALVE TESTS

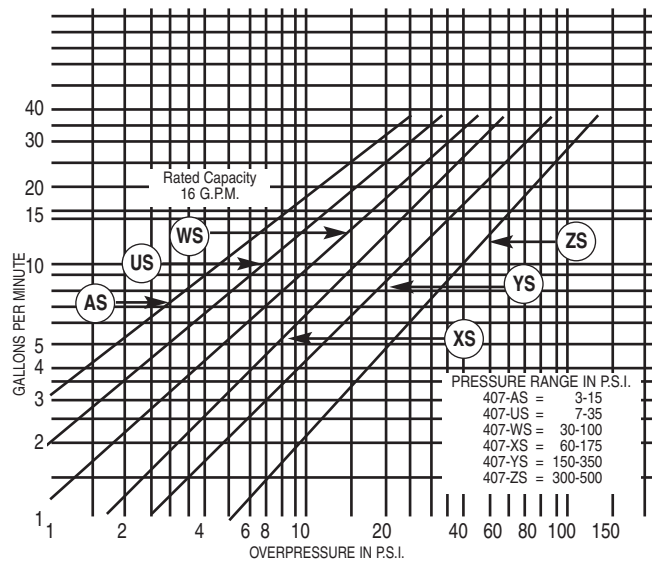

# V-SERIES PERFORMANCE CHARTS

All valve tests 110°F. to 120°F. Oil Viscosity 150 S.S.U. at 100°F.  
(Charts good from 30 to 500 S.S.U.)

1" VALVE TESTS

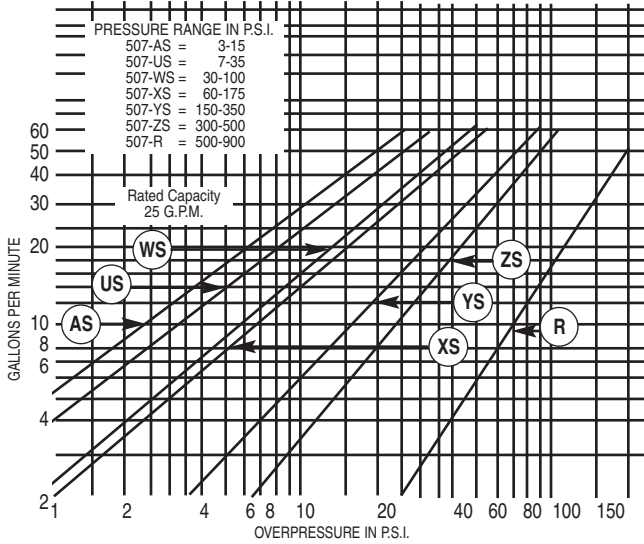

1 1/2" VALVE TESTS

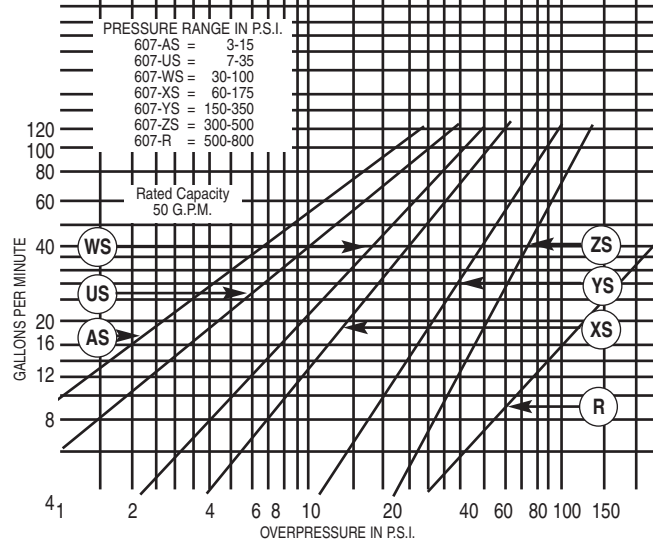

1 1/2" VALVE TESTS

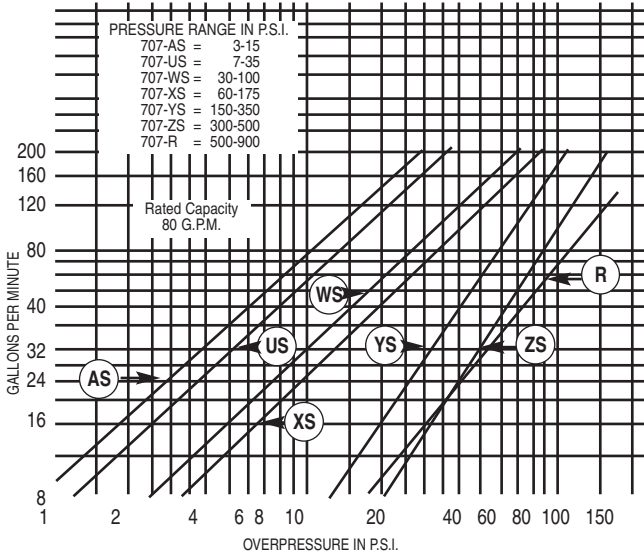

2" VALVE TESTS

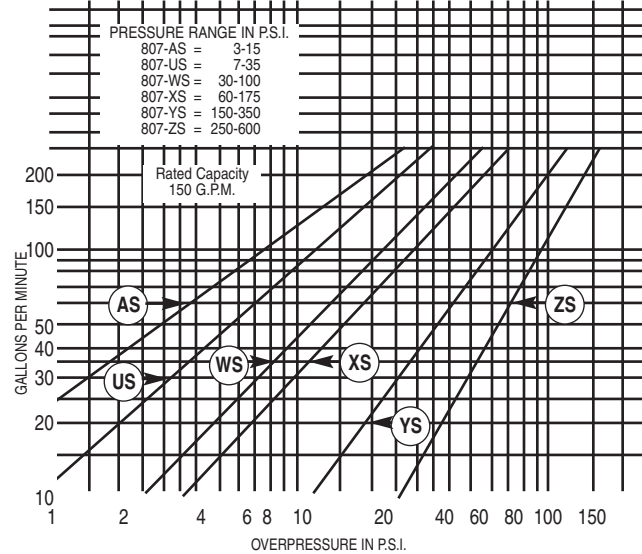

# FV2000 SERIES VALVE



The Fulflo FV2000 Series valve is similar to the V-Series valve, includes a new safer design that protects liquid and gasses from venting out of the valve during normal operation and adjustment conditions. This valve has been

especially designed to prevent the adjusting screw from backing out while making adjustments to the pressure setting. An o-ring has been incorporated around the adjusting screw to further prevent liquid from escaping.

## APPLICATION

The Fulflo “FV” Series range in size from 1/4” through 2” and operate efficiently with liquids of any viscosity at pressures from 2 to 1000 P.S.I. The “FV” series valves are available in flange or screw type... in a choice of brass, cast iron, steel and stainless steel.

Widely used in a variety of applications, the “FV” series valves are ideally suited in hydraulic and lubricating systems for load regulation and system protection. Special trim or packings are available for use with fire resisting fluids and other liquids of this type. Unusual applications and special requirements should be referred to our engineering staff for recommendation.

## INSTALLATION

Fulflo valves can be mounted in any position. A tee may be inserted in the pump discharge line to mount the valve. The correct size of valve should be installed, preferably matching the pump discharge line. Screw the valve into the nipple in the tee, or in the case of the flange style, bolt the valve to the companion flange screwed into the nipple. When the valve is used for frequent bypassing of oil pressure, its outlet

should be piped back to the tank. Care must be taken to have the discharge well below the oil level in the tank to prevent air entrainment and erratic operation.

Only if the valve is used as safety or overload relief and operates infrequently may its discharge be piped back into the pump suction line. Frequent or continuous operation under these conditions will cause excessive heating of the oil and possible damage.

## SETTING VALVES

Valves may be set with a hydraulic hand pump for cracking pressure. If a test stand is available, valve should be connected to the discharge header with the pump bypass open, and the bypass gradually closed until the desired pressure registers on the gauge. Adjust valve adjusting screw until valve slightly bleeds at the set bypass pressure and lock adjusting screw.

Fulflo valves are not designed to be positive shut-off, and will pass a minimal amount of leakage before the set pressure. If a valve is required to bypass a given amount of fluid at a given pressure, a test stand

having a flow meter in the pump discharge line must be available. With a valve adjusted for cracking pressure as above, continue closing bypass until the required flow registers on the flow meter and observe pressure. Readjust pressure, if necessary, to obtain desired pressure at desired flow.

## MAINTENANCE

Fulflo valves provide reliable “chatter-free” operation when the system is free of abrasives and foreign matter. Continuous filtration of the liquid used is strongly recommended.

## TYPICAL DISASSEMBLY OF STANDARD TYPE VALVE

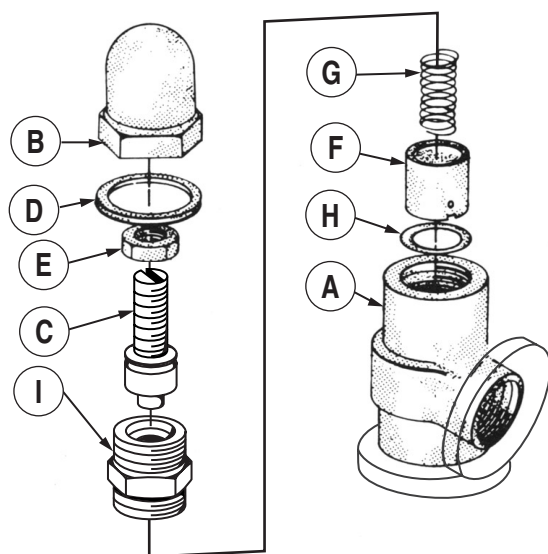

To dismantle valve for inspection cleaning:

1. Remove cap “B”
2. Remove O-Ring “D”
3. Remove lock nut “E”
4. Remove adjusting screw “C”
5. Remove bonnet “I”
6. Remove spring “G”
7. Remove piston “F”
8. Remove stop ring “H” (Not Recommended)  
(Special tooling is required to install new stop ring.)

Inspect valve bore and piston for wear and scoring. Replace broken or damaged parts. Clean all parts thoroughly and re-assemble by reversing the above procedure.

## No Leaking, Dripping, Spills or Venting

The Fulflo FV2000 Series valve includes a new safer design that prevents liquid and gasses from venting out of the valve during normal operation and adjustment conditions. This valve has been especially designed to prevent the adjusting screw from backing out while making adjustments to the pressure setting. An o-ring has been incorporated around the adjusting screw to further prevent liquid from escaping.

## Operates Efficiently and Effectively

The FV2000 Series valves can be mounted in any position with sizes ranging from 1/4” through 2”, and will operate efficiently with any application or viscosity

at pressures from 2 to 1000 psi. Flange or screw connections are available in brass, cast iron, steel or stainless steel. All parts are completely interchangeable and convertible with other Fulflo V-Series valves.

## Fulflo Valve Advantages

These valves offer Fulflo’s patented “chatter-free” performance and are ideally suited for hydraulic and lubricating system protection. All Fulflo valves include a patented modulating piston design with absolute or differential pressure operation. Our advanced modulating operation allows Fulflo valves to be used in many different applications including positive displacement or centrifugal pump and system protection. Fulflo valves can be mounted in any position.



## ASSEMBLY NUMBER IDENTIFICATION CHART

Symbol No.	Designation	Code	Description
1	Series	FV	
2	Material	J B S SS	Cast iron Brass Steel 316 Stainless Steel
3	Connections	None F	Screw Connections Flange Connections 300# Flange Class Standard (250# Flange Class - Cast Iron Standard)
4	Size	-1 -2 -3 -4 -5 -6 -7 -8	1/4" 3/8" 1/2" 3/4" 1" 1 1/4" 1 1/2" 2"
5,6,7	ASA Flange Rating	None -150 -600	300# Flange Standard (no designation required)
8	Flange Style 150# & 600# only	A B C D	Raised Face, Staggered Bolt Centers (standard on all Flange rating) Smooth Face, Staggered Bolt Centers Raised Face, Bolts on Valve Centerline Smooth Face, Bolts on Valve Centerline
9	O-Ring Material	R RV RS RA	Buna O-Ring Cap Seal (standard) Viton O-Ring Cap Seal Silicone O-Ring Cap Seal Atlas O-Ring Cap Seal
10	Piston Material	/HS /SS /3SS	Hardened Steel 416 Stainless Steel 303 Stainless Steel
11	Spring	AS US WS XS YS ZS	
12	Setting		Desired Pressure Setting

### EXAMPLES:

<b>FVJ-1RV/HS/WS</b> FV J -1 RV /HS WS <small>Series Cast Iron 1/4" Viton O-Ring H.S. Piston WS Spring</small>				<b>FVJF-5R/HS/WS</b> FV J F -5 R /HS WS <small>Series Cast Iron Flanged 1" Buna O-Ring H.S. Piston WS Spring</small>				<b>FVJF-5-150AR/HS/WS</b> FV J F -5 -150 A R /HS WS <small>Series Cast Iron Flanged 1" Rating Style Buna O-Ring H.S. Piston WS Spring</small>			
--	--	--	--	--	--	--	--	---	--	--	--

NOTE: Stainless steel pistons are supplied on brass valves, unless hardened steel is specified. Hardened steel pistons are supplied on cast iron or steel unless stainless steel is specified. Buna O-Rings are supplied as standard unless other material is specified.

## STANDARD PRESSURE RANGE CHART

Valve Pipe Size	Valve Flange Size	SPRING PRESSURE AND IDENTIFICATION NO.															
		BLACK-AS		RED-US		GREEN-WS		YELLOW-XS		WHITE-YS		BLUE-ZS		PURPLE-TS		BROWN-RS	
		Low	High	Low	High	Low	High	Low	High	Low	High	Low	High	Low	High	Low	High
1/4"		3	15	7	35	30	100	60	175	150	350	300	500	400	600	550	750
3/8"		3	15	7	35	30	100	60	175	150	350	300	500	400	600	550	750
1/2"		3	15	7	35	30	100	60	175	150	350	300	500	400	600	550	750
3/4"		3	15	7	35	30	100	60	175	150	350	300	500				
1"	1"	3	15	7	35	30	100	60	175	150	350	300	500				
1 1/4"	1 1/4"	3	15	7	35	30	100	60	175	150	350	300	500				
1 1/2"	1 1/2"	3	15	7	35	30	100	60	175	150	350	300	500				
2"	2"	3	15	7	35	30	100	60	175	150	350	250	600				

## DIMENSIONS

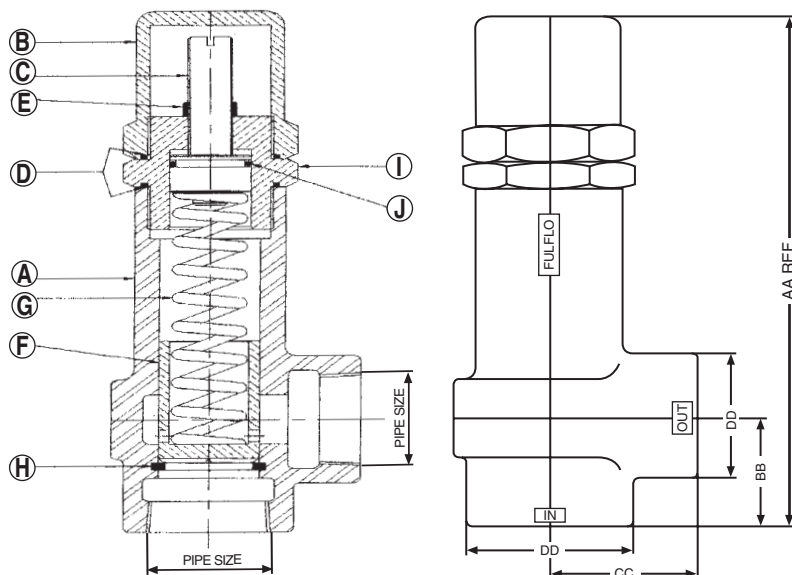

Valve Size	DIMENSIONS IN INCHES			
	AA	BB	CC	DD
1/4"	5 <sup>31</sup> / <sub>32</sub>	1 <sup>11</sup> / <sub>32</sub>	1 <sup>11</sup> / <sub>32</sub>	1 <sup>3</sup> / <sub>8</sub>
3/8"	5 <sup>31</sup> / <sub>32</sub>	1 <sup>11</sup> / <sub>32</sub>	1 <sup>11</sup> / <sub>32</sub>	1 <sup>3</sup> / <sub>8</sub>
1/2"	7 <sup>3</sup> / <sub>32</sub>	1 <sup>11</sup> / <sub>16</sub>	1 <sup>7</sup> / <sub>16</sub>	1 <sup>7</sup> / <sub>16</sub>
3/4"	7 <sup>5</sup> / <sub>16</sub>	1 <sup>15</sup> / <sub>16</sub>	1 <sup>13</sup> / <sub>16</sub>	1 <sup>11</sup> / <sub>16</sub>
1"	9 <sup>1</sup> / <sub>32</sub>	2 <sup>9</sup> / <sub>32</sub>	2 <sup>9</sup> / <sub>32</sub>	2 <sup>1</sup> / <sub>16</sub>
1 1/4"	10 <sup>1</sup> / <sub>16</sub>	2 <sup>9</sup> / <sub>16</sub>	2 <sup>9</sup> / <sub>16</sub>	2 <sup>1</sup> / <sub>2</sub>
1 1/2"	12 <sup>15</sup> / <sub>32</sub>	2 <sup>11</sup> / <sub>16</sub>	2 <sup>11</sup> / <sub>16</sub>	2 <sup>7</sup> / <sub>8</sub>
2"	13 <sup>3</sup> / <sub>4</sub>	3	3	3 <sup>1</sup> / <sub>4</sub>

## PARTS LIST

SYM.	NAME	MODEL	VALVE SIZE							
			1/4"	3/8"	1/2"	3/4"	1"	1 1/4"	1 1/2"	2"
A	BODY	FVJ	100	200	300	400	500	600	700	800
		FVB	100-B	200-B	300-B	400-B	500-B	600-B	700-B	800-B
		FVS	100-S	200-S	300-S	400-S	500-S	600-S	700-S	800-S
		FVSS	100-SS	200-SS	300-SS	400-SS	500-SS	600-SS	700-SS	800-SS
B	CAP	FVJ	201-SR	201-SR	301-SR	401-R	501-R	601-R	701-R	801-R
		FVB	201-BR	201-BR	301-BR	401-BR	501-BR	601-BR	701-BR	801-BR
		FVS	201-SR	201-SR	301-SR	401-SR	501-SR	601-SR	701-SR	801-SR
		FVSS	201-SSR	201-SSR	301-SSR	401-SSR	501-SSR	601-SSR	701-SSR	801-SSR
C	ADJUSTING SCREW	FVJ	202-S8	202-S8	302-S8	402-S8	502-S8	602-S8	702-S8	802-S8
		FVB	202-B8	202-B8	302-B8	402-B8	502-B8	602-B8	702-B8	802-B8
		FVS	202-S8	202-S8	302-S8	402-S8	502-S8	602-S8	702-S8	802-S8
		FVSS	202-SS8	202-SS8	302-SS8	402-SS8	502-SS8	602-SS8	702-SS8	802-SS8
D	O-RING † (2 REQUIRED)	FVJ	204-*	204-*	304-*	404-*	504-*	604-*	704-*	804-*
		FVB	204-*	204-*	304-*	404-*	504-*	604-*	704-*	804-*
		FVS	204-*	204-*	304-*	404-*	504-*	604-*	704-*	804-*
		FVSS	204-*	204-*	304-*	404-*	504-*	604-*	704-*	804-*
E	LOCK NUT	FVJ	205-S	205-S	305-S	305-S	505-S	505-S	505-S	505-S
		FVB	205-S	205-S	305-S	305-S	505-S	505-S	505-S	505-S
		FVS	205-S	205-S	305-S	305-S	505-S	505-S	505-S	505-S
		FVSS	205-SS	205-SS	305-SS	305-SS	505-SS	505-SS	505-SS	505-SS
F	PISTON †	HARDENED STEEL	206	206	306	406	506	606	706	806
		416 STAINLESS STEEL	206-A	206-A	306-A	406-A	506-A	606-A	706-A	806-A
		303 STAINLESS STEEL	206-SS	206-SS	306-SS	406-SS	506-SS	606-SS	706-SS	806-SS
G	SPRING †	ALL MODELS	207-**	207-**	307-**	407-**	507-**	607-**	707-**	807-**
H	STOP RING	FVJ	208-S	208-S	308-S	408-S	508-S	608-S	708-S	808-S
		FVB	208-B	208-B	308-B	408-B	508-B	608-B	708-B	808-B
		FVS	208-S	208-S	308-S	408-S	508-S	608-S	708-S	808-S
		FVSS	208-SS	208-SS	308-SS	408-SS	508-SS	608-SS	708-SS	808-SS
I	BONNET	FVJ	223-S4	223-S4	323-S4	423-S4	523-S4	623-S4	723-S4	823-S4
		FVB	223-B4	223-B4	323-B4	423-B4	523-B4	623-B4	723-B4	823-B4
		FVS	223-S4	223-S4	323-S4	423-S4	523-S4	623-S4	723-S4	823-S4
		FVSS	223-SS4	223-SS4	323-SS4	423-SS4	523-SS4	623-SS4	723-SS4	823-SS4
J	O-RING † (1 REQUIRED)	FVJ	7058-*	7058-*	7006-*	7025-*	7003-*	7061-*	7062-*	504-*
		FVB	7058-*	7058-*	7006-*	7025-*	7003-*	7061-*	7062-*	504-*
		FVS	7058-*	7058-*	7006-*	7025-*	7003-*	7061-*	7062-*	504-*
		FVSS	7058-*	7058-*	7006-*	7025-*	7003-*	7061-*	7062-*	504-*

\* See o-ring selection chart

\*\* See spring pressure chart

† Recommended spare parts

## DIMENSIONS

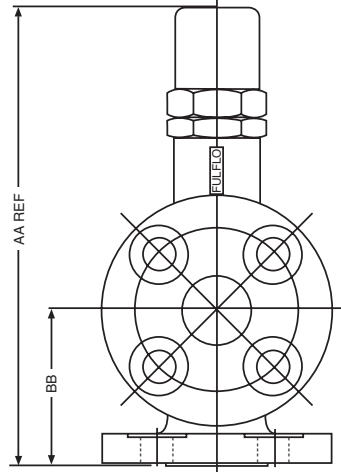
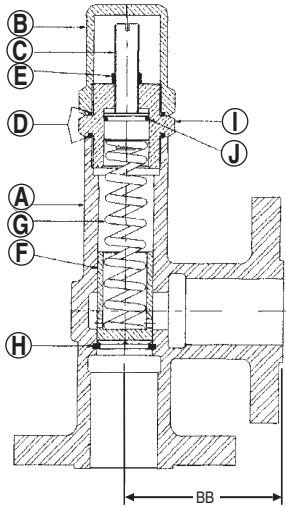

### DIMENSIONS IN INCHES

Valve Size	AA	BB
1"	10 <sup>5</sup> / <sub>16</sub> "	3 <sup>1</sup> / <sub>2</sub> "
1 <sup>1</sup> / <sub>4</sub> "	11 <sup>13</sup> / <sub>16</sub> "	3 <sup>3</sup> / <sub>4</sub> "
1 <sup>1</sup> / <sub>2</sub> "	12 <sup>5</sup> / <sub>8</sub> "	4 <sup>1</sup> / <sub>16</sub> "
2"	15 <sup>5</sup> / <sub>16</sub> "	4 <sup>9</sup> / <sub>16</sub> "

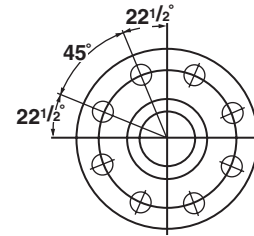

FOR 2" VALVE ONLY

## PARTS LIST

SYM.	NAME	MODEL	VALVE SIZE			
			1"	1 <sup>1</sup> / <sub>4</sub> "	1 <sup>1</sup> / <sub>2</sub> "	2"
A	BODY	FVJF FVBF FVSF FVSSF	500-F 500-BF 500-SF 500-SSF	600-F 600-BF 600-SF 600-SSF	700-F 700-BF 700-SF 700-SSF	800-F 800-BF 800-SF 800-SSF
B	CAP	FVJF FVBF FVSF FVSSF	501-R 501-BR 501-SR 501-SSR	601-R 601-BR 601-SR 601-SSR	701-R 701-BR 701-SR 701-SSR	801-R 801-BR 801-SR 801-SSR
C	ADJUSTING SCREW	FVJF FVBF FVSF FVSSF	502-S8 502-B8 502-S8 502-SS8	602-S8 602-B8 602-S8 602-SS8	702-S8 702-B8 702-S8 702-SS8	802-S8 802-B8 802-S8 802-SS8
D	O-RING † (2 REQUIRED)	FVJF FVBF FVSF FVSSF	504- 504- 504- 504-	604- 604- 604- 604-	704- 704- 704- 704-	804- 804- 804- 804-
E	LOCK NUT	FVJF FVBF FVSF FVSSF	505-S 505-S 505-S 505-SS	505-S 505-S 505-S 505-SS	505-S 505-S 505-S 505-SS	505-S 505-S 505-S 505-SS
F	PISTON †	HARDENED STEEL 416 STAINLESS STEEL 303 STAINLESS STEEL	506 506-A 506-SS	606 606-A 606-SS	706 706-A 706-SS	806 806-A 806-SS
G	SPRING †	ALL MODELS	507-**	607-**	707-**	807-**
H	STOP RING	FVJF FVBF FVSF FVSSF	508-S 508-B 508-S 508-SS	608-S 608-B 608-S 608-SS	708-S 708-B 708-S 708-SS	808-S 808-B 808-S 808-SS
I	BONNET	FVJF FVBF FVSF FVSSF	523-S4 523-B4 523-S4 523-SS4	623-S4 623-B4 623-S4 623-SS4	723-S4 723-B4 723-S4 723-SS4	823-S4 823-B4 823-S4 823-SS4
J	O-RING † (1 REQUIRED)	FVJF FVBF FVSF FVSSF	7003- 7003- 7003- 7003-	7061- 7061- 7061- 7061-	7062- 7062- 7062- 7062-	504- 504- 504- 504-

\* See o-ring selection chart

\*\* See spring pressure chart

† Recommended spare parts

All valve tests 110°F. to 120°F. Oil Viscosity 150 S.S.U. at 100°F.  
(Charts good from 30 to 500 S.S.U.)

1/4" VALVE TESTS

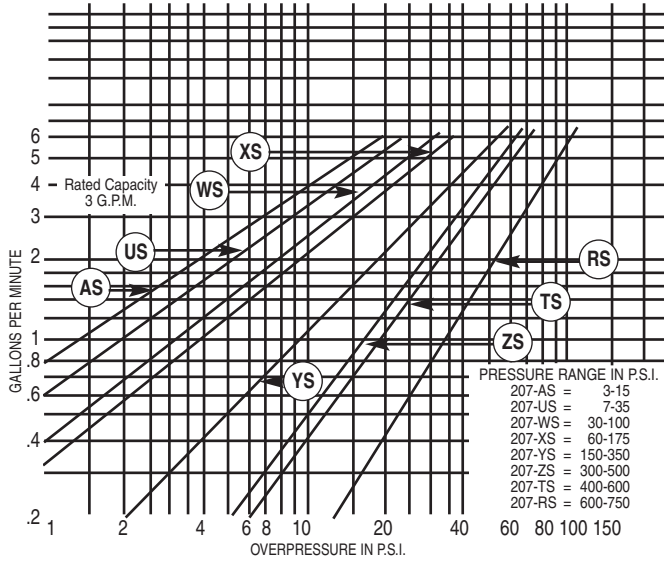

3/8" VALVE TESTS

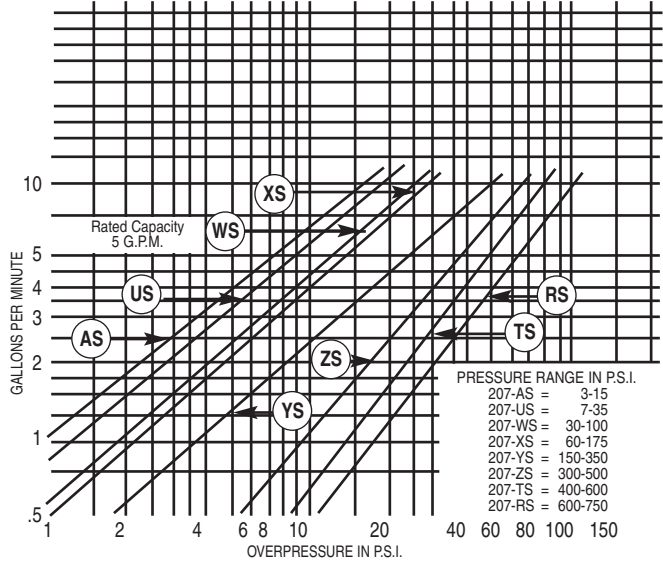

1/2" VALVE TESTS

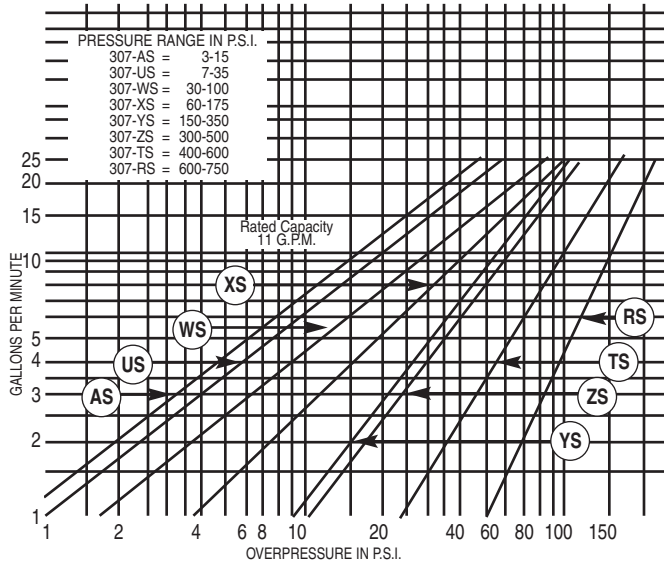

3/4" VALVE TESTS

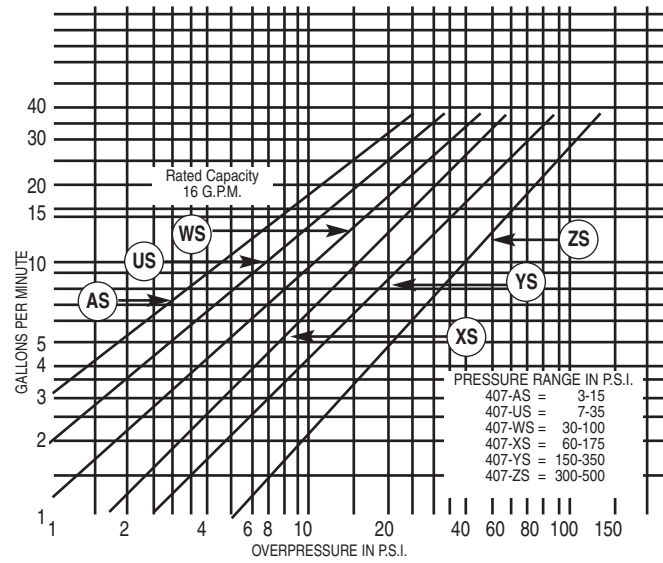

# FV-SERIES

All valve tests 110°F. to 120°F. Oil Viscosity 150 S.S.U. at 100°F.  
(Charts good from 30 to 500 S.S.U.)

FV-SERIES  
VALVES

1" VALVE TESTS

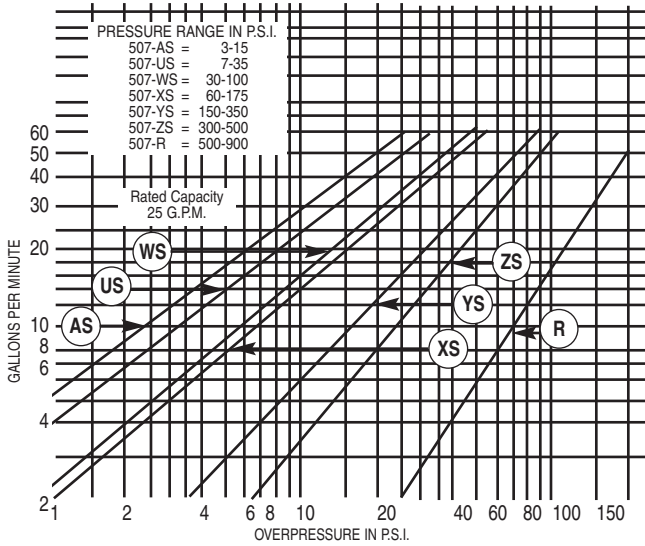

1 1/4" VALVE TESTS

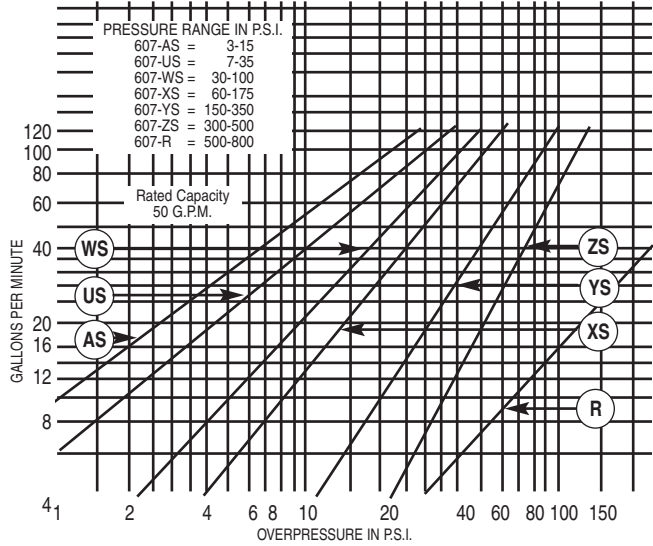

1 1/2" VALVE TESTS

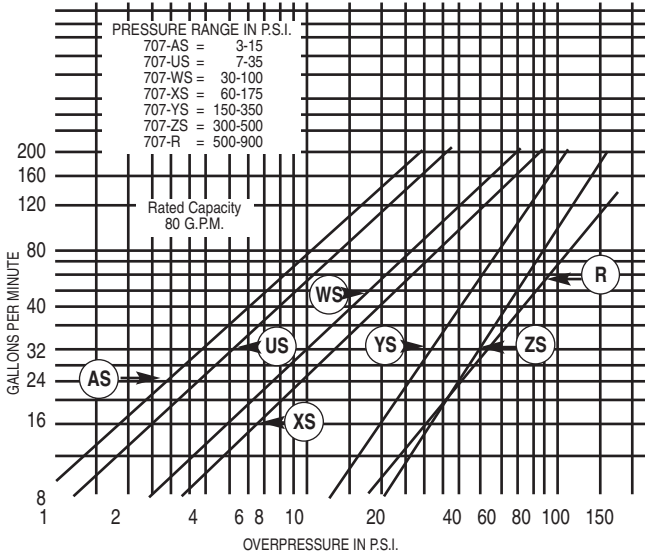

2" VALVE TESTS

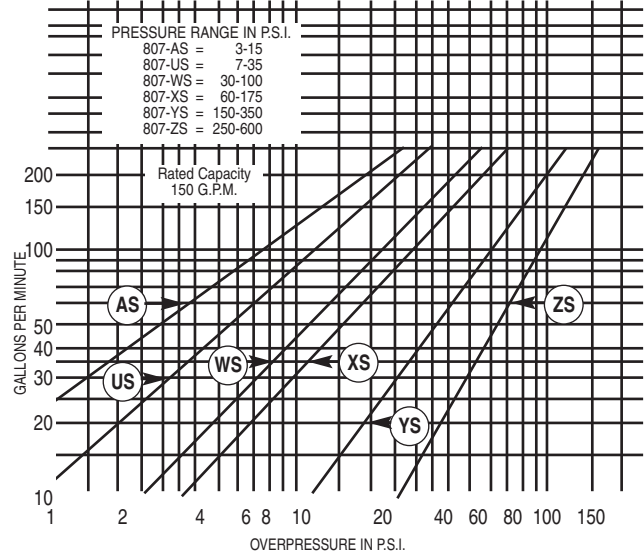

# A-SERIES VALVES

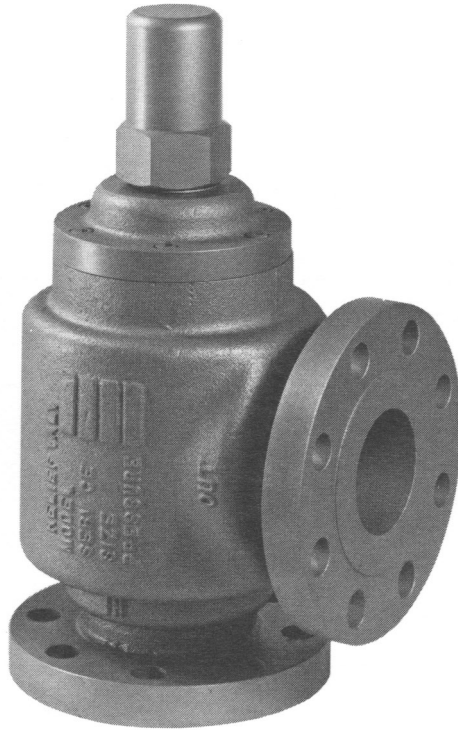

## APPLICATION

The Fulflo "A" Series feature both direct acting and internal pilot operated models with either screw or flange type connections. The threaded valves are available in both 2½" and 3" sizes in either cast iron or steel. The flange type valves also include a 4" model and may be specified with 150#, 300# or 600# ANSI flanges.

The direct acting valves operate at pressures to 150 P.S.I.; the internal pilot operated models at

pressures to 500 P.S.I. Both types handle large flows of liquid of all viscosities encountered in industrial practice.

The "A" Series valves may be used in a variety of applications including hydraulic and lubrication systems for load regulation and system protection.

Unusual applications and special or stainless steel requirements should be referred to our engineering staff for recommendation.

## INSTALLATION

Fulflo valves can be mounted in any position. A tee may be inserted in the pump discharge line to mount the valve. The pipe lines carrying the heavy valves must be well supported and overhung weights avoided. The correct size of valve must be used, preferably equal to the size of the pipe line to which they are connected. Threaded valves (AAD and ACD) may be

threaded into pipe nipples. Overhung weights on threads should be avoided. Flanged valves (AADF and ACDF) are bolted to the companion flange which may be threaded or welded to the pipe. The outlet of the valve should be piped to the supply tank, unless specific applications call for alternate piping of return lines. Care must be taken to have the discharge well below the oil level in the tank to prevent air entrainment and erratic operation.



## SETTING VALVES

Valve may be set with a hydraulic hand pump for cracking pressure. If a test stand is available, valve should be connected to the discharge header with the pump bypass open, and the bypass gradually closed until the desired pressure registers on the gauge. **“Direct”** Adjust valve adjusting screw until valve slightly bleeds at the set bypass pressure and lock adjusting screw. **“Pilot”** Adjust valve adjusting screw until approximately 5-7 GPM is flowing through the valve, at that point the main piston will open and then the valve will be considered at the cracking point, then lock adjusting screw. If a valve is required to bypass a given amount of fluid at a

given pressure, a test stand having a flow meter in the pump discharge line must be available. With a valve adjusting for cracking pressure as above, continue closing bypass until the required flow registers on the flow meter and observe pressure. Readjust pressure, if necessary, to obtain desired pressure at desired flow.

## MAINTENANCE

Fulflo valves provide reliable “chatter-free” operation when the system is free of abrasives and foreign matter. Continuous filtration of the liquid used is strongly recommended.

## DISASSEMBLY OF DIRECT ACTING VALVES

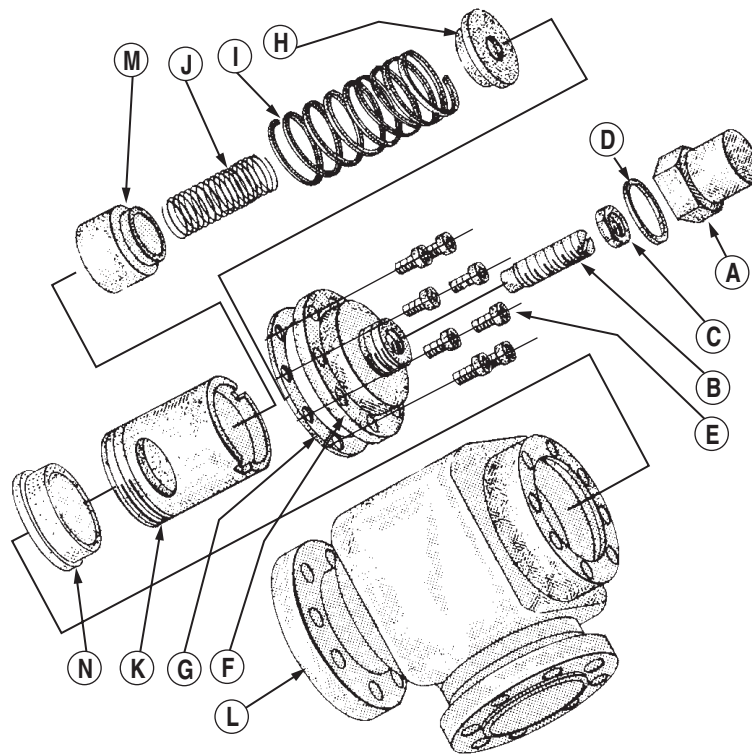

To dismantle the valve for inspection or cleaning:

1. Remove cap “A” and gasket “D”
2. Remove lock nut “C”
3. Remove adjusting screw “B”
4. Remove cap screws “E”
5. Remove bonnet “F”
6. Remove gasket “G”
7. Remove spring retainer “H”
8. Remove spring or springs “I” and “J”
9. Remove piston “M”
10. Unscrew and withdraw cylinder “K”

11. Remove retaining bushing “N” if necessary

Inspect cylinder bore and piston for wear or scoring. Replace broken or damaged parts. Clean all parts thoroughly and re-assemble as follows:

Reverse process of disassembly from operation 11 to 6, then thread adjusting screw “B” into bonnet “F” so that it may be guided into the recess of spring retainer “H”, while re-assembling bonnet “F” to body “L”. Then proceed with steps 5, 4, 2, 1, in reverse order.

## ASSEMBLY NUMBER IDENTIFICATION CHART

Symbol No.	Designation	Code	Description
1	Series	A	
2	Material	A C	Cast Iron Cast Steel
3	Type	D P	Direct Acting Internal Pilot Operated
4 & 5	Size	09 10 11	2 1/2" 3" 4"
6	Connection	None F	Screw Type Flange
7,8,9	ASA Flange Rating	150# 300# 600#	
10	Flange Style Only	A B C D	Raised Face, Staggered Bolt Centers (Standard) Smooth Face, Staggered Bolt Centers Raised Face, Bolts on Valve Centerline Smooth Face, Bolts on Valve Centerline
11	O-Ring Material	R RV RS RT RA	Buna O-Ring Cap Seal (Standard) Viton O-Ring Cap Seal Silicone O-Ring Cap Seal Teflon O-Ring Cap Seal Atlas O-Ring Cap Seal

### EXAMPLE:

<b>ACP09</b>			
A	C	P	09
Series	Steel	Pilot Operated	2 1/2"

NOTE: Special valves are prefixed by numbers assigned by the factory.

### EXAMPLE:

Specify:

1. Valve Model Number
2. O-Ring Identification Number
3. Piston Material
4. Spring Part Number
5. Spring pressure range or desired pressure setting.

### SERIES "A" VALVES (Direct Acting) PRESSURE RANGE CHART

Valve Size	Symbol	Spring Part No.	Pressure Range
2 1/2"	I	A0960D	7-57 P.S.I.
	I	A0961C	8-75 P.S.I.
	I & J	A0960D and A0970D	14-115 P.S.I.
	I & J	A0961C and A0971C	16-150 P.S.I.
3"	I	A1060D	5-50 P.S.I.
	I	A1061C	5-67 P.S.I.

NOTE: Springs suffixed with "C" are Chrome Vanadium, "D" indicates Stainless Steel. For pressures other than listed, consult factory.

### (Continued)

3"	I & J	A1060D and A1070D	10-100 P.S.I.
	I & J	A1061C A1071C	10-135 P.S.I.
4"	I	A1160D	2-37 P.S.I.
	I & J	A1160D and A1170D	4-75 P.S.I.

### SERIES "A" VALVES (Pilot Operated) PRESSURE RANGE CHART

Valve Size	Symbol	Spring Part No.	Pressure Range
2 1/2"	O & J	A0980D and A1190D	50-500 P.S.I.
3"	O & J	A1080D and A1190D	50-500 P.S.I.
4"	O & J	A1181D and A1190D	50-500 P.S.I.

### DIMENSIONS

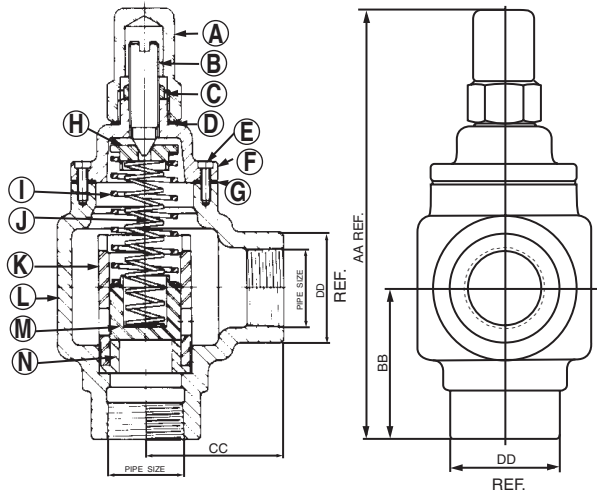

Valve Size	DIMENSIONS IN INCHES			
	AA	BB	CC	DD
2 1/2"	15 <sup>9</sup> / <sub>16</sub>	5 1/2	5 1/16	4
3"	17 1/2	6 <sup>5</sup> / <sub>8</sub>	6 <sup>3</sup> / <sub>8</sub>	4 <sup>7</sup> / <sub>8</sub>

### PARTS LIST

Symbol	NAME	VALVE SIZE	
		2 1/2"	3"
A	Cap	A1101CR	A1013CR
B	Adjusting Screw	A0922C	A1022C
C	Lock Nut	605-S	705-S
D	O-Ring †	604-R	704-R
E	Cap Screw	3/8 x 1 SHCS	3/8 x 1 SHCS
F	Bonnet Cast Iron Steel	A0909A A0909C	A1009A A1009C
G	Gasket †	A0903E	A1003E
H	Spring Retainer	A0916C	A1016C
I	Spring †	See Chart	See Chart
J	Spring †	See Chart	See Chart
K	Cylinder †	A0908C	A1008C
L	Body Cast Iron Steel	A0900A A0900C	A1000A A1000C
M	Piston † Hardened Steel Stainless Steel	A0906C A0906D	A1006C A1006D
N	Retaining Bushing	A0911C	A1011C

† Recommended spare parts

# A-SERIES 2½", 3" and 4" (Direct Acting)

## DIMENSIONS

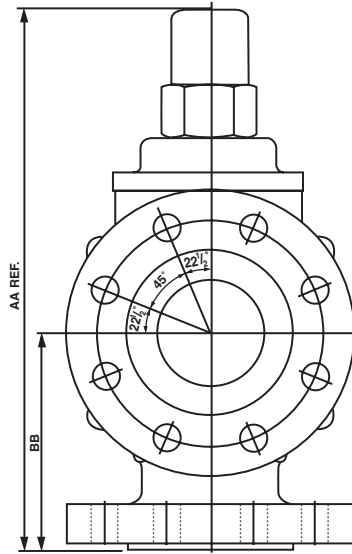
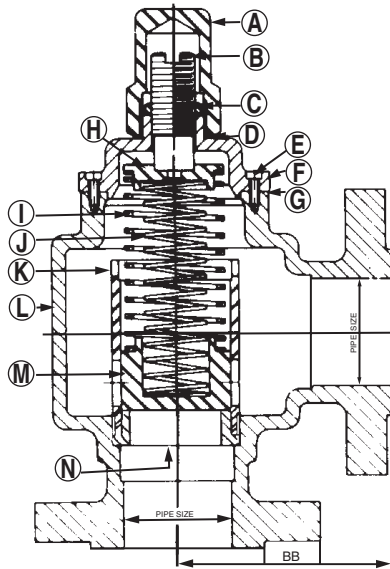

DIMENSIONS IN INCHES

Valve Size	Flange Rating	AA	BB
2½	150# 300#	15 <sup>12</sup> / <sub>16</sub>	5 <sup>3</sup> / <sub>4</sub>
2½	600#	16 <sup>3</sup> / <sub>16</sub>	6 <sup>1</sup> / <sub>8</sub>
3	150# 300#	17 <sup>1</sup> / <sub>8</sub>	6 <sup>1</sup> / <sub>4</sub>
3	600#	17 <sup>1</sup> / <sub>2</sub>	6 <sup>5</sup> / <sub>8</sub>
4	150# 300#	20	7 <sup>15</sup> / <sub>16</sub>
4	600#	20 <sup>3</sup> / <sub>16</sub>	8 <sup>1</sup> / <sub>8</sub>

Note! Refer to Page 10 for Flange and Drilling Dimensions.

## PARTS LIST

Symbol	NAME	VALVE SIZE			
		2½"	3"	4"	
A	Cap	A1101CR	A1013CR	A1113CR	
B	Adjusting Screw	A0922C	A1022C	A1122C	
C	Lock Nut	605-S	705-S	805-S	
D	O-Ring †	604-R	704-R	804-R	
E	Cap Screw	3/8 x 1 SHCS	3/8 x 1 SHCS	3/8 x 1 SHCS	
F	Bonnet Cast Iron Steel	A0909A A0909C	A1009A A1009C	A1109A A1109C	
G	Gasket †	A0903E	A1003E	A1103E	
H	Spring Retainer	A0916C	A1016C	A1116C	
I	Spring †	See Chart	See Chart	See Chart	
J	Spring †	See Chart	See Chart	See Chart	
K	Cylinder †	A0908C	A1008C	A1108C	
L	Body	Cast Iron 150# 300# 600# Steel 150# 300# 600#	A0900AF150A A0900AF300A A0900AF600A A0900CF150A A0900CF300A A0900CF600A	A1000AF150A A1000AF300A A1000AF600A A1000CF150A A1000CF300A A1000CF600A	A1100AF150A A1100AF300A A1100AF600A A1100CF150A A1100CF300A A1100CF600A
M	Piston † Hardened Steel Stainless Steel	A0906C A0906D	A1006C A1006D	A1106C A1106D	
N	Retaining Bushing	A0911C	A1011C	A1111C	

† Recommended spare parts

A-SERIES  
VALVES

# A-SERIES PERFORMANCE CHARTS

(Direct Acting)

All valve tests 110°F. to 120°F. Oil Viscosity 150 S.S.U. at 100°F.  
(Charts good from 30 to 500 S.S.U.)

2 1/2" VALVE TESTS

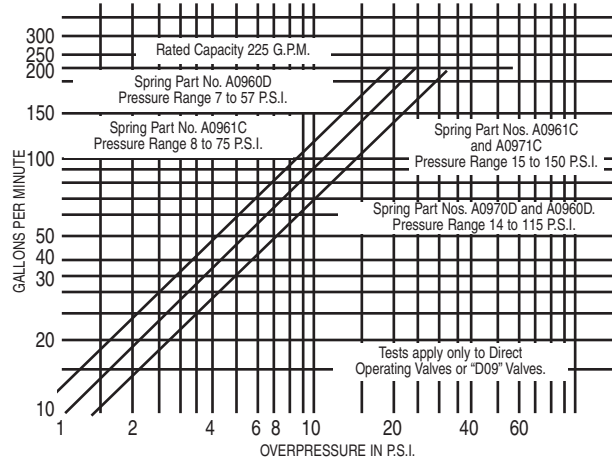

3" VALVE TESTS

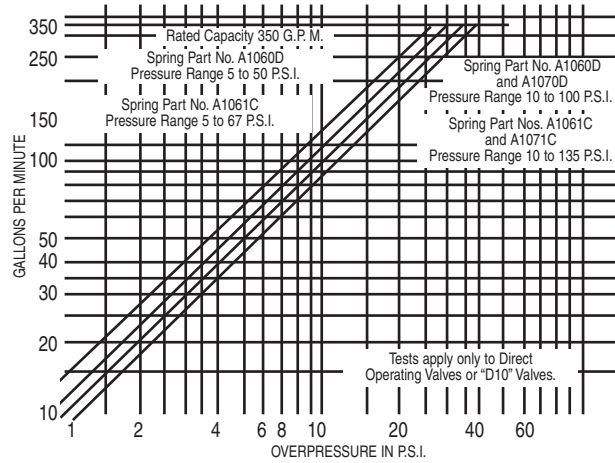

4" VALVE TESTS

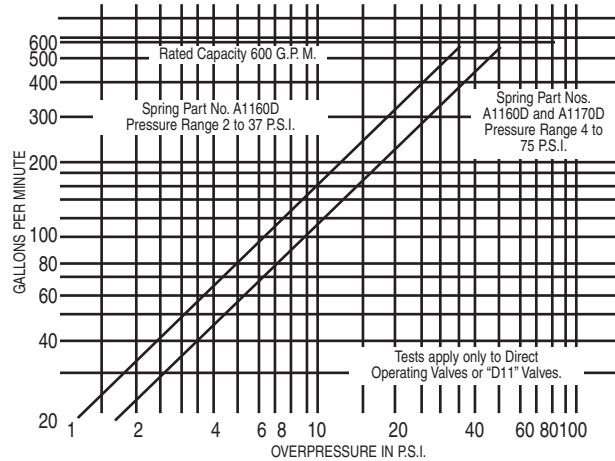

A-SERIES VALVES

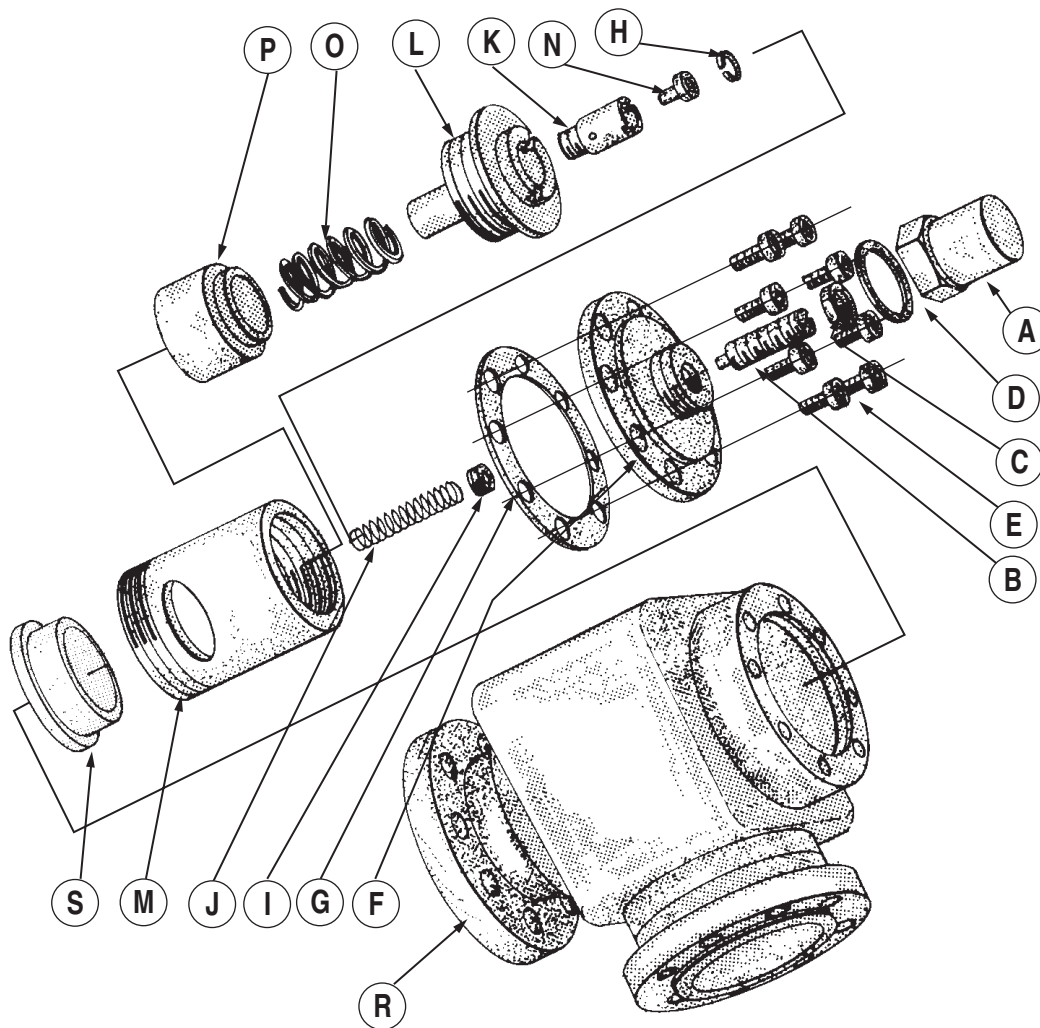

## DISASSEMBLY OF INTERNAL PILOT OPERATED VALVES

To dismantle the valve for inspection or cleaning:

1. Remove cap "A" and gasket "D"
2. Remove nut "C"
3. Remove adjusting screw "B"
4. Remove cap screws "E"
5. Remove bonnet "F"
6. Remove gasket "G"
7. Remove spring retainer "I"
8. Remove pilot spring "J"
9. Unscrew and withdraw cylinder "M" (do not unscrew cylinder retainer "L")
10. Unscrew and remove cylinder retainer "L", after removing cylinder "M".
- Caution:** hold in vise. Balance spring "O" under heavy compression.
11. Unscrew and remove piston retainer "K"

12. Remove retaining ring "H"
13. Remove pilot piston "N"
14. Remove balance spring "O"
15. Remove piston "P"
16. Remove retaining bushing "S" if necessary

Inspect bores of both piston retainer "K" and cylinder "M". Inspect pistons "N" and "P" for wear or scoring. Replace broken or damaged parts. Clean all parts thoroughly and re-assemble as follows:

Reverse process of disassembly from operation 16 to 6, then thread adjusting screw "B" into bonnet "F" so that it may be guided into the recess of spring retainer "I", while re-assembling "F" to body "R". Then proceed with steps 5, 4, 2, 1 in reverse order.

# A-SERIES 2½" and 3" (Internal Pilot Operated)

## DIMENSIONS

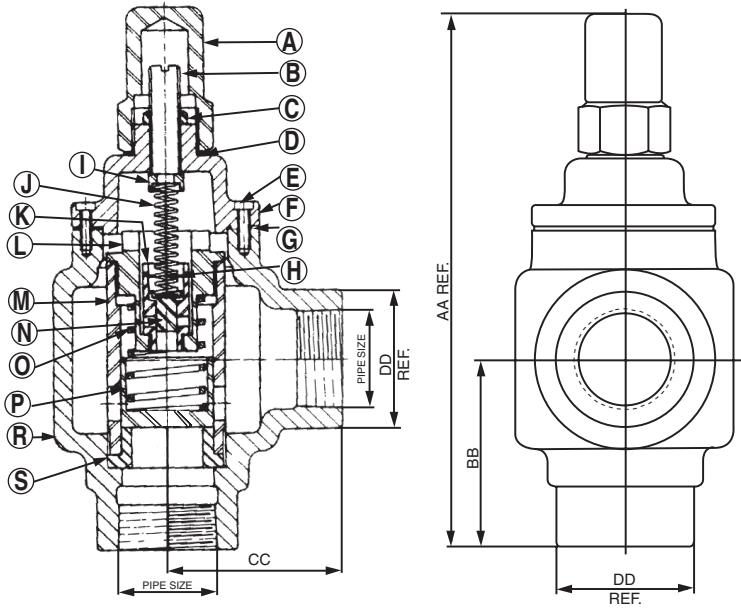

Valve Size	DIMENSIONS IN INCHES			
	AA	BB	CC	DD
2½"	15 <sup>5</sup> / <sub>8</sub>	5½	5 <sup>1</sup> / <sub>16</sub>	4
3"	16½	6 <sup>5</sup> / <sub>8</sub>	6 <sup>3</sup> / <sub>8</sub>	4 <sup>7</sup> / <sub>8</sub>

## PARTS LIST

Symbol	NAME	VALVE SIZE	
		2½"	3"
A	Cap	A1101CR	A1101CR
B	Adjusting Screw	A1102C	A1102C
C	Lock Nut	505-S	505-S
D	O-Ring †	604-R	604-R
E	Cap Screw	3/8 x 1 SHCS	3/8 x 1 SHCS
F	Bonnet Cast Iron Steel	A0919A A0919C	A1019A A1019C
G	Gasket †	A0903E	A1003E
H	Retainer Ring †	A1120D	A1120D
I	Spring Retainer	A1126C	A1126C
J	Pilot Spring †	A1190D	A1190D
K	Piston Retainer †	A1118C	A1118C
L	Cylinder Retainer	A0912C	A1012C
M	Cylinder †	A0928C	A1028C
N	Pilot Piston † Hardened Steel Stainless Steel	A1115C A1115D	A1115C A1115D
O	Balance Spring †	A0980D	A1080D
P	Piston † Hardened Steel Stainless Steel	A0936C A0936D	A1036C A1036D
R	Body Cast Iron Steel	A0900A A0900C	A1000A A1000C
S	Retaining Bushing	A0911C	A1011C

† Recommended spare parts



# A-SERIES 2½", 3" and 4" (Internal Pilot Operated)

## DIMENSIONS

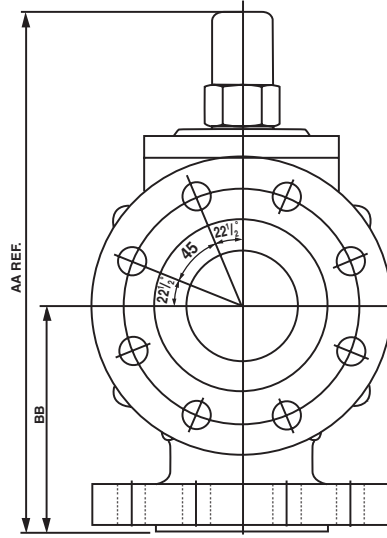
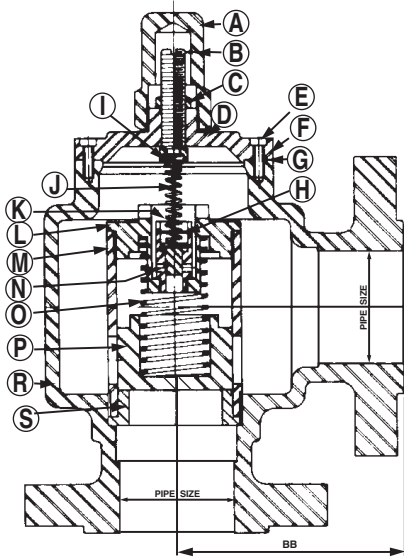

DIMENSIONS IN INCHES

Valve Size	Flange Rating	AA	BB
2½	150# 300#	15 <sup>7</sup> / <sub>8</sub>	5 <sup>3</sup> / <sub>4</sub>
2½	600#	16 <sup>1</sup> / <sub>4</sub>	6 <sup>1</sup> / <sub>8</sub>
3	150# 300#	16 <sup>1</sup> / <sub>8</sub>	6 <sup>1</sup> / <sub>4</sub>
3	600#	16 <sup>1</sup> / <sub>2</sub>	6 <sup>5</sup> / <sub>8</sub>
4	150# 300#	18 <sup>3</sup> / <sub>16</sub>	7 <sup>15</sup> / <sub>16</sub>
4	600#	18 <sup>3</sup> / <sub>8</sub>	8 <sup>1</sup> / <sub>8</sub>

## PARTS LIST

Symbol	NAME	VALVE SIZE		
		2½"	3"	4"
A	Cap	A1101CR	A1101CR	A1101CR
B	Adjusting Screw	A1102C	A1102C	A1102C
C	Lock Nut	505-S	505-S	505-S
D	O-Ring †	604-R	604-R	604-R
E	Cap Screw	3/8 x 1 SHCS	3/8 x 1 SHCS	3/8 x 1 SHCS
F	Bonnet Cast Iron Steel	A0919A A0919C	A1019A A1019C	A1119A A1119C
G	Gasket †	A0903E	A1003E	A1103E
H	Retainer Ring †	A1120D	A1120D	A1120D
I	Spring Retainer	A1126C	A1126C	A1126C
J	Pilot Spring †	A1190D	A1190D	A1190D
K	Piston Retainer †	A1118C	A1118C	A1118C
L	Cylinder Retainer	A0912C	A1012C	A1112C
M	Cylinder †	A0928C	A1028C	A1128C
N	Pilot Piston † Hardened Steel Stainless Steel	A1115C A1115D	A1115C A1115D	A1115C A1115D
O	Balance Spring †	A0980D	A1080D	A1181D
P	Piston † Hardened Steel Stainless Steel	A0936C A0936D	A1036C A1036D	A1136C A1136D
R	Body Cast Iron Steel	150# 300# 600# 150# 300# 600#	A0900AF150A A0900AF300A A0900AF600A A0900CF150A A0900CF300A A0900CF600A	A1000AF150A A1000AF300A A1000AF600A A1000CF150A A1000CF300A A1000CF600A
S	Retaining Bushing	A0911C	A1011C	A1111C

† Recommended spare parts

A-SERIES  
VALVES

# A-SERIES PERFORMANCE CHARTS

(Internal Pilot Operated)

All valve tests 110°F. to 120°F. Oil Viscosity 150 S.S.U. at 100°F.  
 (Charts good from 30 to 500 S.S.U.)

2 1/2" VALVE TESTS

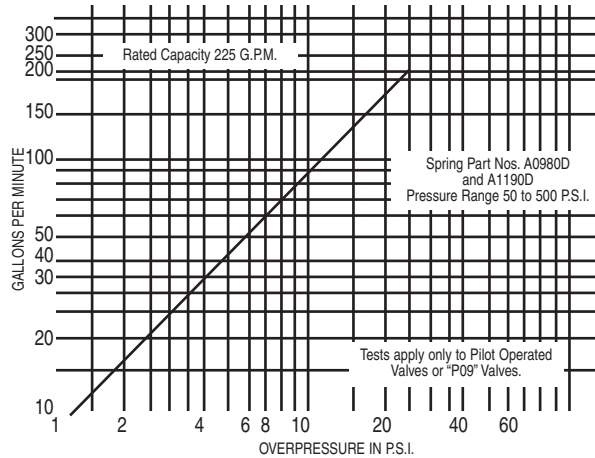

3" VALVE TESTS

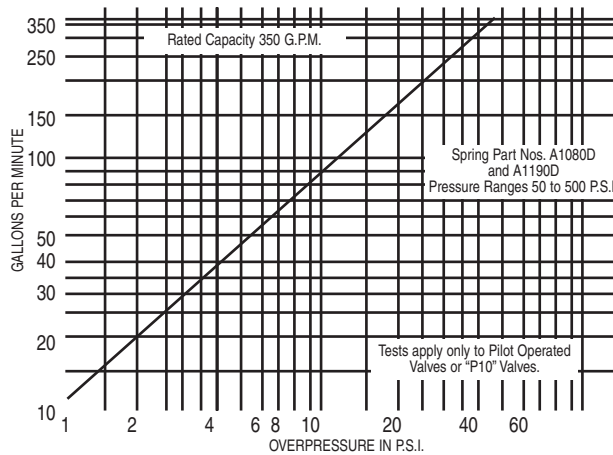

4" VALVE TESTS

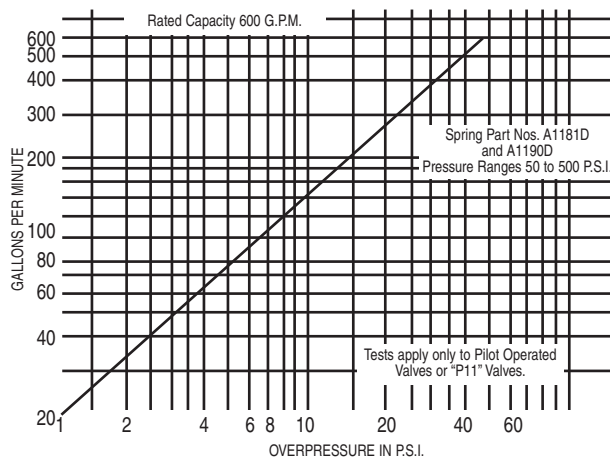

A-SERIES VALVES

# SVB-SERIES VALVES\*

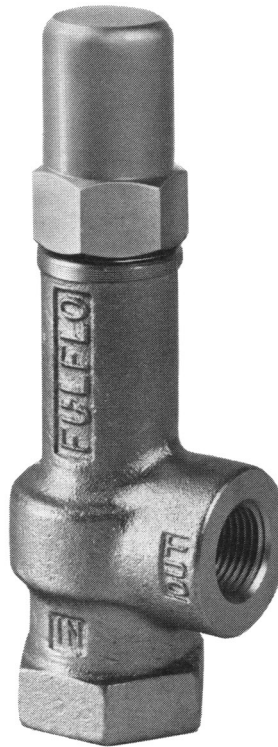

\*Underwriter Listed

## APPLICATION

The Fulflo "SVB" Series, Underwriter Listed, range in size from 1/4" through 1" and operate efficiently with liquids of any viscosity at pressures from 7 through 500 P.S.I. The "SVB" valves are of brass construction with threaded connections.

Primarily designed for use with fuel oils on oil burner service, the "SVB" valves may be used wherever Underwriter Listed valves are required. Each valve is pre-set to the specified pressure and is equipped with a limiting device to prevent over-adjustment.

## INSTALLATION

Fulflo valves can be mounted in any position. A tee may be inserted in the pump discharge line to mount the valve. The correct size of valve should be installed, preferably matching the pump discharge line. Screw the valve into the nipple in the tee. When the valve is used for frequent bypassing of oil under pressure, its outlet should be piped back to the tank. Care

must be taken to have the discharge well below the oil level in the tank to prevent air entrainment and erratic operations.

Only if the valve is used as safety or overload relief and operates infrequently may its discharge be piped back into the pump suction line. Frequent or continuous operation under these conditions will cause excessive heating of the oil and possible damage.

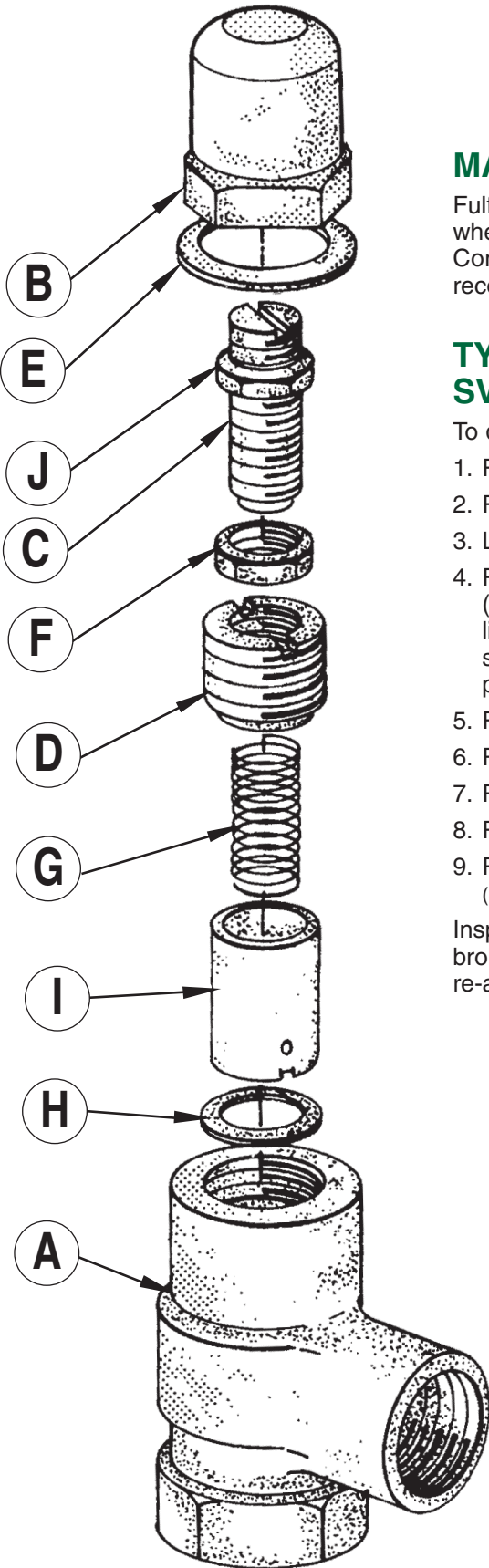

## MAINTENANCE

Fulflo valves provided reliable "chatter-free" operation when the system is free of abrasives and foreign matter. Continuous filtration of the liquid used is strongly recommended.

## TYPICAL DISASSEMBLY OF SVB VALVES

To dismantle valve for inspection and cleaning:

1. Remove cap "B"
2. Remove gasket "E" (replace, if necessary)
3. Loosen lock nut "F"
4. Remove adjusting screw "C"  
(Limit collar "J" is soldered to adjusting screw "C", to limit the maximum pressure to which the valve may be subjected.) Limit collar is set at 25% above normal pressure setting.
5. Remove lock nut "F"
6. Remove retainer "D"
7. Remove spring "G"
8. Remove piston "I"
9. Remove stop ring "H" (Not Recommended)  
(Special tooling is required to install new stop ring.)

Inspect valve bore and piston for wear or scoring. Replace broken or damaged parts. Clean all parts thoroughly and re-assemble by reversing the above procedure.

## ASSEMBLY NUMBER IDENTIFICATION CHART

Symbol Number	Designation	Code	Description
1	Style	S	Underwriter Listed
2	Series	V	–
3	Material	B	Brass
4 or 5	Size	-15 -25 -35 -45 -55	1/4" 3/8" 1/2" 3/4" 1"
6	Spring	See Chart	See Spring Pressure Chart
7	Piston	0 1 2 3	Hardened Steel, deep groove Stainless Steel, deep groove Hardened Steel, shallow groove Stainless Steel, shallow groove

### EXAMPLE:

<b>SVB-55ZSO</b>					
S	V	B	-55	ZS	O
Underwriter's Listed	Series	Brass	1"	Spring	Hardened Steel Piston, Deep Groove

### HOW TO ORDER

Specify:

1. Valve Model Number
2. Spring Letter
3. Piston Number
4. Pressure Setting

NOTE: A definite pressure setting is required due to Underwriter restrictions. A limiting device is furnished to prevent over-adjustment more than 25% above set pressure.

### SETTING VALVES

Valve may be set with a hand pump for cracking pressure. It will be noted that the maximum set pressure is limited by the collar "J" soldered to the adjusting screw "C".

If a test stand is available, valve should be connected to the discharge header with the pump bypass open, and the bypass gradually closed until the desired pressure registers on the gauge. Adjust valve adjusting screw until valve slightly bleeds at the set bypass pressure and lock adjusting screw.

If valve is required to bypass a given amount of fluid at a given pressure, a test stand having a flow meter in the pump discharge line must be available. With valve adjusted for cracking pressure as above, continue closing bypass until the required flow registers on the flow meter and observe pressure. Re-adjust pressure, if necessary, to obtain desired pressure at desired flow.

## UNDERWRITER VALVE PRESSURE RANGE CHART

Pipe Size	"U.L." Symbol	SPRING PRESSURE RANGE AND PART NO. SUFFIX									
		RED-US		GREEN-WS		YELLOW-XS		WHITE-YS		BLUE-ZS	
		Low	High	Low	High	Low	High	Low	High	Low	High
1/4"	SVB-15	7	35	30	100	60	175	150	350	300	500
3/8"	SVB-25	7	35	30	100	60	175	150	350	300	500
1/2"	SVB-35	7	35	30	100	60	175	150	350	300	500
3/4"	SVB-45	7	35	30	100	60	175	150	350	300	500
1"	SVB-55	7	35	30	100	60	175	150	350	300	500

# SVB-SERIES (Brass)

## DIMENSIONS

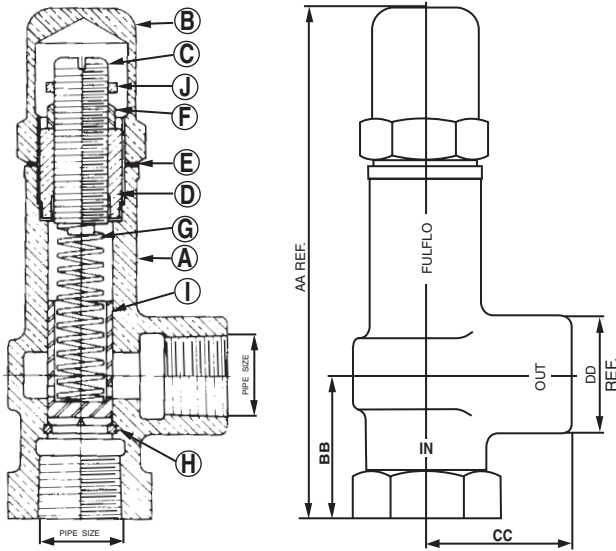

Pipe Size	"U.L." Symbol	DIMENSIONS IN INCHES			
		AA	BB	CC	DD
1/4"	SVB-15	5 <sup>11</sup> / <sub>32</sub>	1 <sup>11</sup> / <sub>32</sub>	1 <sup>11</sup> / <sub>32</sub>	1 <sup>3</sup> / <sub>8</sub>
3/8"	SVB-25	5 <sup>11</sup> / <sub>32</sub>	1 <sup>11</sup> / <sub>32</sub>	1 <sup>11</sup> / <sub>32</sub>	1 <sup>3</sup> / <sub>8</sub>
1/2"	SVB-35	6 <sup>3</sup> / <sub>16</sub>	1 <sup>11</sup> / <sub>16</sub>	1 <sup>7</sup> / <sub>16</sub>	1 <sup>7</sup> / <sub>16</sub>
3/4"	SVB-45	6 <sup>15</sup> / <sub>16</sub>	1 <sup>15</sup> / <sub>16</sub>	1 <sup>13</sup> / <sub>16</sub>	1 <sup>11</sup> / <sub>16</sub>
1"	SVB-55	8 <sup>7</sup> / <sub>32</sub>	2 <sup>9</sup> / <sub>32</sub>	2 <sup>9</sup> / <sub>32</sub>	2 <sup>1</sup> / <sub>16</sub>

## PARTS LIST

Symbol	NAME	VALVE SIZE				
		1/4"	3/8"	1/2"	3/4"	1"
A	Body	100-B	200-B	300-B	400-B	500-B
B	Cap	201-B	201-B	301-B	401-B	501-B
C	Adjusting Screw	202-B	202-B	302-B	402-B	502-B
D	Retainer	203-B	203-B	303-B	403-B	503-B
E	Gasket	204	204	304	404	504
F	Lock Nut	205-S	205-S	305-S	405-S	505-S
G	Spring	See Chart	See Chart	See Chart	See Chart	See Chart
H	Stop Ring	208-B	208-B	308-B	408-B	508-B
I	Piston Hardened Steel Stainless Steel	206 206-A	206 206-A	306 306-A	406 406-A	506 506-A
J	Limit Collar	221-B	221-B	321-B	421-B	521-B



# SVB-SERIES PERFORMANCE CHARTS

All valve tests 110°F. to 120°F. Oil Viscosity 150 S.S.U. at 100°F.  
(Charts good from 30 to 500 S.S.U.)

1/4" VALVE TESTS

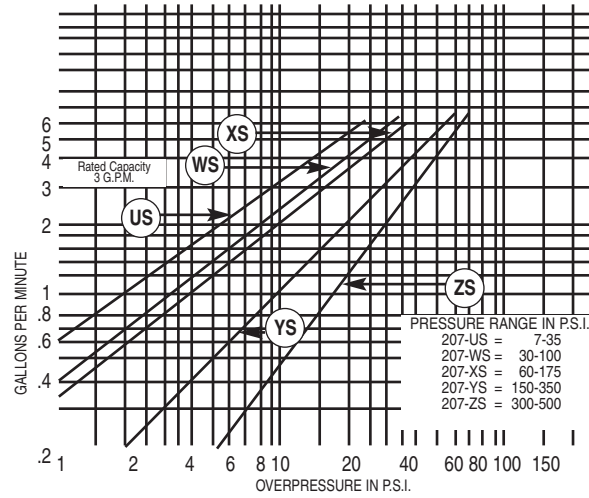

3/8" VALVE TESTS

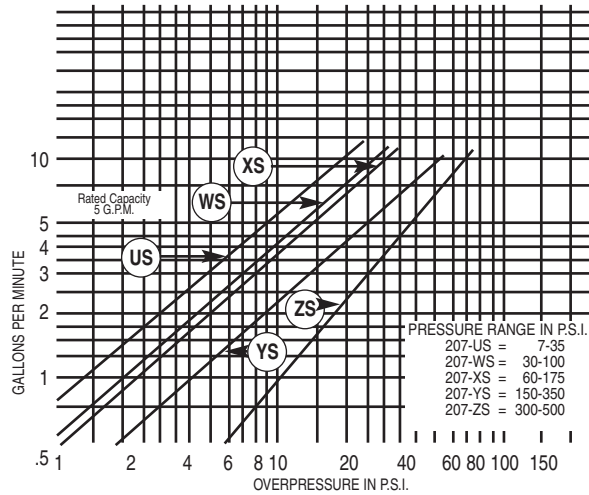

1/2" VALVE TESTS

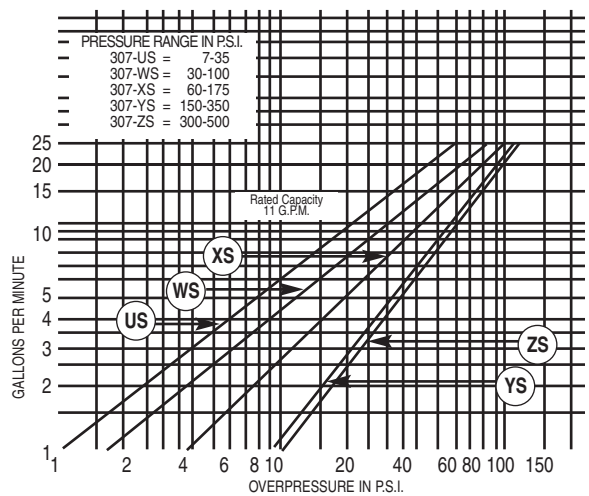

SVB-SERIES  
VALVES

# SVB-SERIES PERFORMANCE CHARTS

All valve tests 110°F. to 120°F. Oil Viscosity 150 S.S.U. at 100°F.  
(Charts good from 30 to 500 S.S.U.)

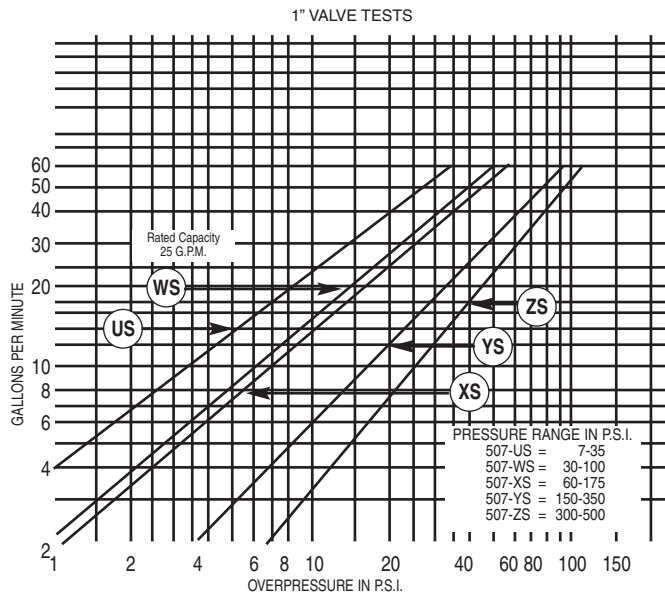
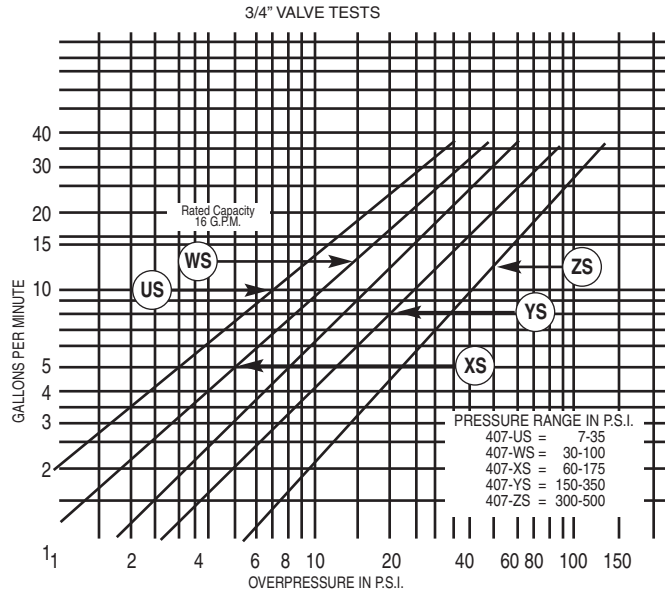

# TYPICAL APPLICATIONS

## Combustion Equipment

- Circulating Oil Systems
- Heating Equipment on Railroad Cars
- Package and Industrial Boilers
- Oil Burning Equipment

## Machine Tools

- Valves are used for:
  - Regulation of Lubricating System Pressure
  - Regulation of Pressure for Hydraulic Feeds
  - Regulation of Coolant Pressure
- Boring Machines
- Drills (Radial, Single or Multiple Spindle)
- Grinders (Surface, Cylindrical, Centerless and Universal)
- Lathes (Engine, Turret, Automatic)
- Milling Machines
- Hydraulic Tracing Units

## Hydraulic Manufacturing and Processing Equipment

- Stamping Presses
- Press Brakes
- Molding Presses
- Rams
- Crushers
- Bending and Forming Equipment

## Hydraulic Test Stands

- To Maintain Specific Pressures
- As Safety Relief Valve to Protect Pumps, Gauges, etc.
- Aircraft Test Equipment and Ground Support Equipment
- Equipment Test Racks
- Pressure Test Racks

## Hydraulic Power Units

- Used in Basic Tank, Pump and Motor Systems

## Material Handling Equipment

- Hydraulic Hoists
- Hydraulic Elevators
- Hydraulic Platforms

## Special Equipment

- Fire Equipment
- Laundry Equipment
- Coal Mining Equipment
- Road Spraying Machinery
- Car Washing Machinery
- Cleaning Machinery (Steam or Solution)
- Industrial Sewing Machines
- Dairy Machinery
- Special and Custom Engineered Industrial Machinery
- Equipment for Oxygen and Industrial Gasses

## Industrial Air Conditioning Equipment

- Pumps - Filters

## Engines and Turbines, Lubrication and Control System

- Diesel Engines
- Steam Turbines
- Hydraulic Turbines
- Gas Turbines

## Mobile Equipment Industrial Compressors

## Processing Systems

- Public Utilities
  - Maintaining City Water System Pressures
  - Protection and Control of Fire Hydrant Pressures
- Oil Refineries
- Chemical Plants
- Distilleries
- Irrigation Systems
- Steel Mill and Processing Plants
- Food Processing Plants
- Papermill and Pulp Processing Plants

## Liquids Handled

- Hydraulic Oils
- Water (Treated, Purified and Salt Water)
- Dry Cleaning Solvent
- Heated Tar (Pumped)
- Heated Molasses (Pumped)
- Anhydrous Ammonia
- Edible Fats and Oils
- Processed Liquid Foods
- Processed Petroleum Products